

2 off VG8 Ovens  
Stacked  
with low stand (CRLS)

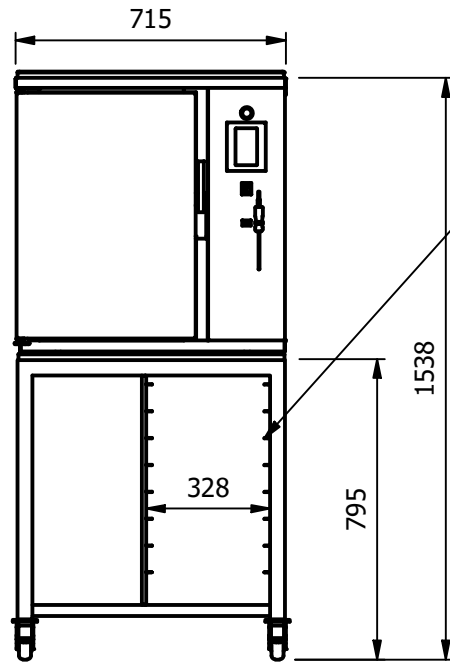

1 off VG8 Oven  
with high stand (CRHS)

Bank of runners for Gn type pans

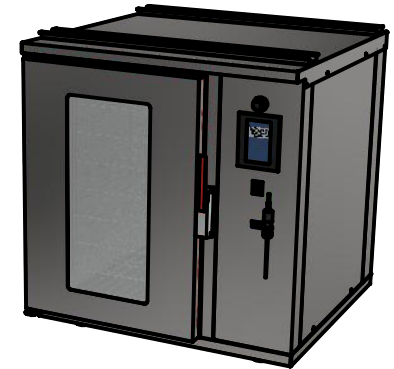
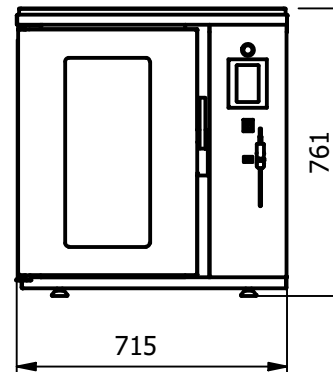
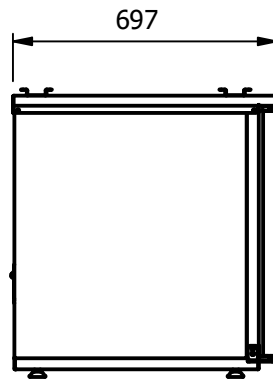
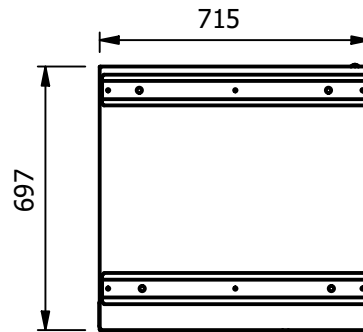

**Moffat Specification**

Dimensions

Width - 715mm  
Depth - 695mm  
Height - 761mm  
Weight - 130kg

Power Rating options

2.9kw  
complete with a 2m long cord set & 13amp plug.  
5.7 kw.  
complete with a 2m long cord set & 32amp plug.

Materials

1.2mm 304 & 430 Grade St/ Steel Top & Supports.  
0.7 & 1.2mm 430 Grade St Steel Ancillary Parts.

Fully insulated compartment  
with internal illumination and double glazed door.

Control

Fully Programmably For 24/7 Operation.  
Three Set Meal Programmes With  
Boost, Hold, Pre heat, & Cleaning Functions.

Oven

Capacity 98litres  
8off Gn1/1 Grid shelf positions @ 71mm pitch

ALL SHEET METAL DIMENSIONS ARE I/S (INSIDE SIZES) (UNLESS OTHERWISE STATED)

ALL DIMENSIONS IN (mm), TOLERANCE = LINEAR ± 0.5mm, ANGULAR ± 0.5mm (OR AS STATED). ALL SHARP EDGES TO BE REMOVED FROM SHEET METAL PARTS

Product	VGEN 2018			Product No			
Description	VG8G						
Material/Finish	Thickness			Desp/Date			
Legacy P/N	Weight	130kg		Quote No.			
Client				SO Number	N/A		
Client Project				Approved By			
				Dwg No.	VGEN-089127		Issue
				Drawn By	ABB		-
				Date	12/10/2018		
E & R MOFFAT LTD, SEABEGS ROAD, BONNYBRIDGE, FK4 2BS, T: +44 (0)1324 812272, E: sales@ermoffat.co.uk, Web: www.ermoffat.co.uk				Scale	1 : 20		Sheet 1 / 2 <b>A4</b>

No reproduction or publication of this drawing may be made, and no article may be manufactured or assembled in accordance with this drawing without prior written consent. This prohibition is a term of any contract relating to this drawing. Rights reserved under the Copyright Act 1956 as amended by the Design Copyright Act 1968.

