

NOTE:- Serving height for children up to 12 years of age.
This model is available with a work top height of 800mm
and a Trayslide height of 773mm.
Please add "B" to the end of the product code.

Moffat Specification

Wet heat Bainmarie well
Water level is an economic, 20mm deep with a water level mark on the well, complete with drain valve and swing-out run-off tube for easy emptying. The well has a raised lip designed to hold Gastronorm pans and heats via solid state elements fitted under the well, additional excess residual hot air from the hot cupboard is also used to maintain temperature which gives energy savings.

Dry Heat
Fan Assisted Hotcupboard

Dimensions
Width - 1814mm
Depth - 680mm
Height - 900mm
Weight - 125kg



Sahara Fan Model SF309

Capacity of Bainmarie
Five GN1/1 pans up to 150mm deep
[Note:-pans are not supplied, available at extra cost]

Capacity of Hot Cupboard [usable inside space]
Width - 1679mm
Depth - 555mm
Usable Height Bottom shelf - 204mm
Usable Height Top Shelf - 245mm

60 covers & meals
[10" plated meals stacked using plate covers]
or
228 off 10" plates stacked for heating
or
10 off 1/1GN pans side by side 150mm deep
5 on top 5 on bottom

Power Rating
2.90kw with no gantry, 3.78Kw with heated gantry.
complete with a 2m long cord set & 32amp plug
Removable Fan heating System Sahara Fan Model SF309

Materials
1.2mm 304 Grade St/ Steel Top & Supports
0.7mm 430 Grade St/ Steel Internal Structure
GN 1/1 Grid Shelves with 30mm x 30mm tube supports

Installation
All swivel castors, two braked

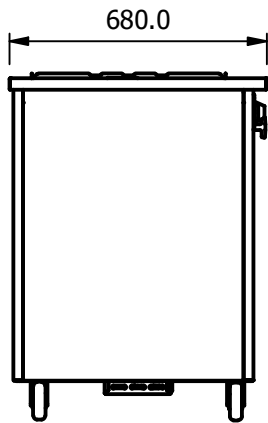
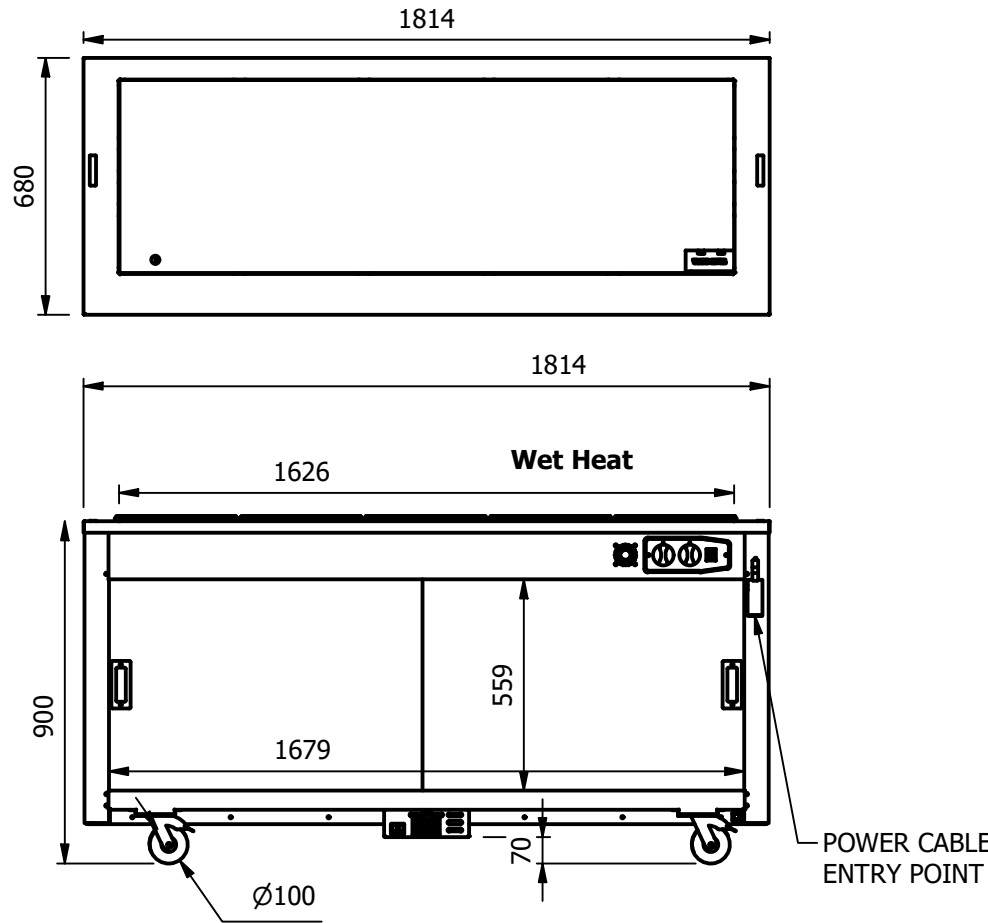

ALL SHEET METAL DIMENSIONS ARE I/S (INSIDE SIZES) (UNLESS OTHERWISE STATED)

ALL DIMENSIONS IN (mm), TOLERANCE = LINEAR ± 0.5mm, ANGULAR ± 0.5mm (OR AS STATED). ALL SHARP EDGES TO BE REMOVED FROM SHEET METAL PARTS

| | | | | | | | |
|---|----------------|-------|--|--|----------|------------|-----------|
| Product | VERSICARTE | | | Product No | N/A | | |
| Description | *** VC5BMW *** | | | <small>No reproduction or publication of this drawing may be made, and no article may be manufactured or assembled in accordance with this drawing without prior written consent. This prohibition is a term of any contract relating to this drawing. Rights reserved under the Copyright Act 1956 as amended by the Design Copyright Act 1968.</small> | | | |
| Material/Finish | Thickness | | | Desp/Date | | | |
| Legacy P/N | Weight | 125kg | | Quote No. | Dwg No. | VCP-084986 | Issue |
| Client | | | | SO Number | STANDARD | | Drawn By |
| Client Project | | | | Approved By | Date | 28/10/2019 | - |
| E & R MOFFAT LTD, SEABEGS ROAD, BONNYBRIDGE, FK4 2BS, T: +44 (0)1324 812272, E: sales@ermoffat.co.uk, Web: www.ermoffat.co.uk | | | | | | Scale | 1 : 20 |
| | | | | | | Sheet | 1 / 1 |
| | | | | | | | A4 |

