

Important Design Parameters

Allowances must be made for air venting.  
The under slung compressor must have an unrestricted air flow.  
Proper venting must be provided ensuring cool air from the room can be drawn in through the condensing coil and out the other side.

Warning

Do not install unit in draughty conditions where the air movement is greater than 0.2mtr/sec.  
e.g. near entrance/exit doors, open windows, under air conditioning units or a ceiling mounted fan  
Do not install units where there is high radiated heat, e.g. direct sunlight, room heaters, or bright spot lights.  
Ambient room conditions must not exceed 25°C or a relative humidity of 60%.  
Blocked vents will cause reduced refrigeration efficiency and lead to malfunction

NOTE:- Serving height for children up to 12 years of age.  
This model is available with a work top height of 800mm and a Trayslide height of 773mm.  
Please add "B" to the end of the product code.

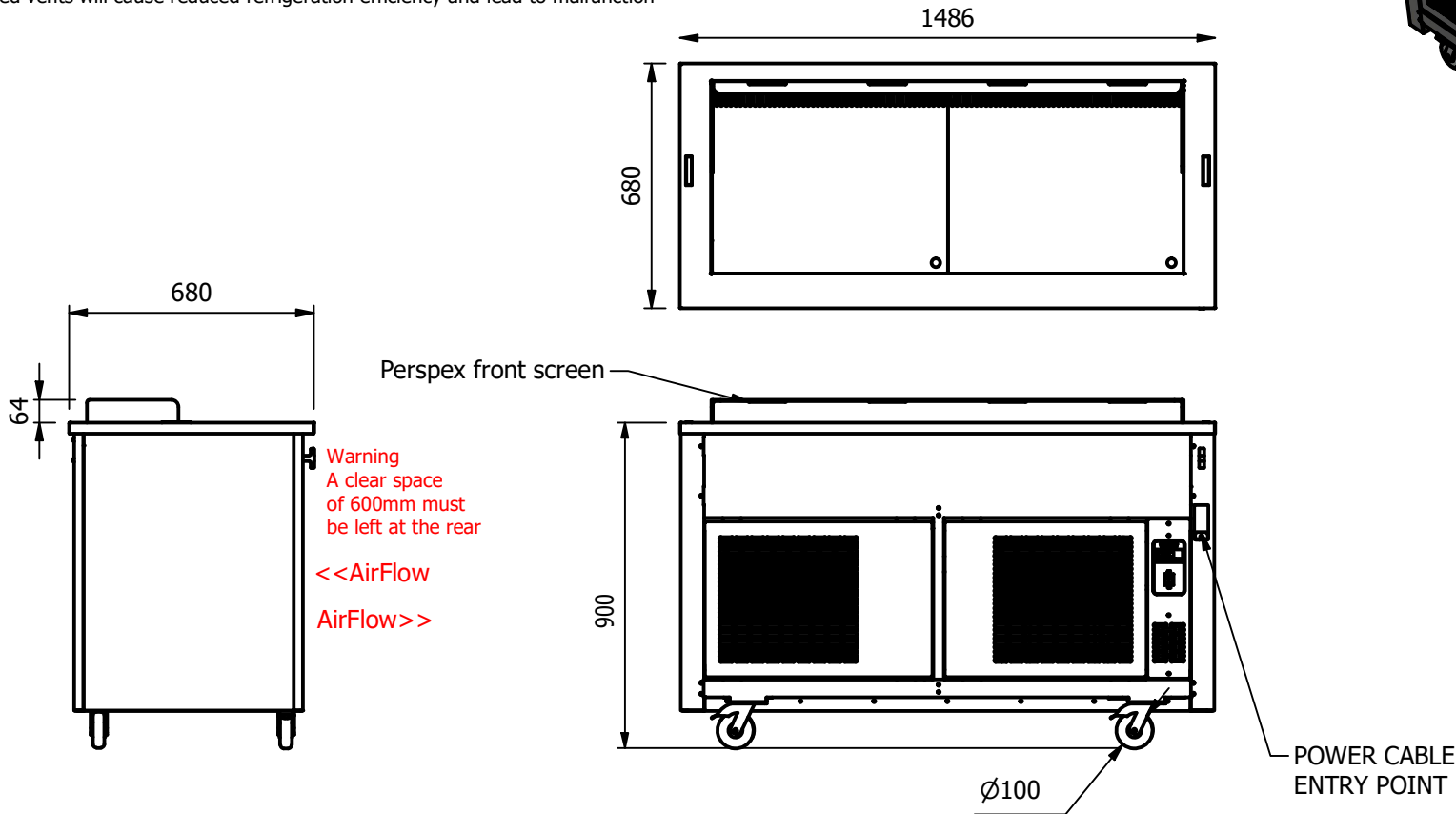
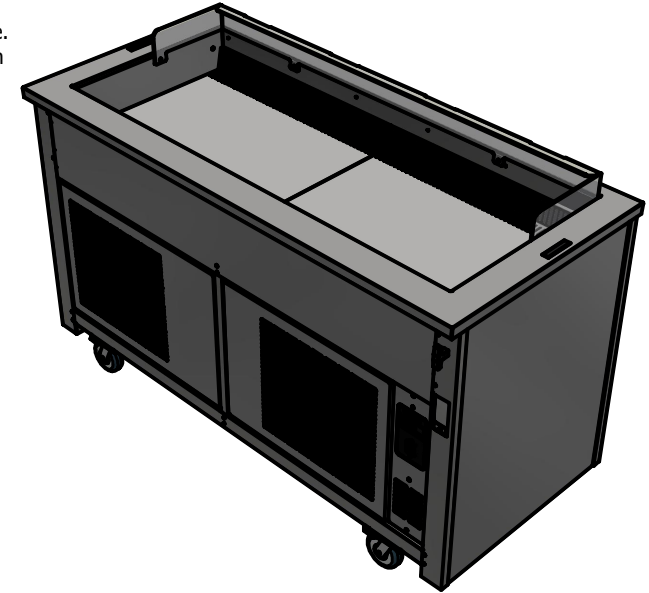

**Moffat Specification**

Dimensions

Width - 1486mm  
Depth - 680mm  
Height - 900mm  
Weight - 155kg  
Well - 1312mm x 535mm x 130mm

Power Rating

1.2kw  
complete with a 2m long cord set & 13amp plug

Materials

0.7mm 430 Grade St/Steel Gantry Hood  
1.2mm 304 Grade St/ Steel Top & Supports  
1.2mm 430 Grade St Steel Ancillary Parts  
6mm Tempered Glass  
LED Illumination

Installation

All swivel castors, two braked

ALL SHEET METAL DIMENSIONS ARE I/S (INSIDE SIZES) (UNLESS OTHERWISE STATED)

ALL DIMENSIONS IN (mm), TOLERANCE = LINEAR ± 0.5mm, ANGULAR ± 0.5mm (OR AS STATED). ALL SHARP EDGES TO BE REMOVED FROM SHEET METAL PARTS

Product	VERSICARTE			Product No							
Description	*** VC4RWNG ***										
Material/Finish	Thickness			Desp/Date							
Legacy P/N	Weight	155kg		Quote No.							
Client				SO Number	STANDARD		Dwg No.	VCP-086171	Issue		
Client Project				Approved By			Drawn By	ABB	-		
							Date	04/07/2023			
E & R MOFFAT LTD, SEABEGS ROAD, BONNYBRIDGE, FK4 2BS, T: +44 (0)1324 812272, E: sales@ermoffat.co.uk, Web: www.ermoffat.co.uk							Scale	1 : 20	Sheet	1 / 2	<b>A4</b>

No reproduction or publication of this drawing may be made, and no article may be manufactured or assembled in accordance with this drawing without prior written consent. This prohibition is a term of any contract relating to this drawing. Rights reserved under the Copyright Act 1956 as amended by the Design Copyright Act 1968.

