

Important Design Parameters

Allowances must be made for air venting.
The under slung compressor must have an unrestricted air flow.
Proper venting must be provided ensuring cool air from the room can be drawn in through the condensing coil and out the other side.

Warning

Do not install unit in draughty conditions where the air movement is greater than 0.2mtr/sec.
e.g. near entrance/exit doors, open windows, under air conditioning units or a ceiling mounted fan
Do not install units where there is high radiated heat, e.g. direct sunlight, room heaters, or bright spot lights.
Ambient room conditions must not exceed 25°C or a relative humidity of 60%.
Blocked vents will cause reduced refrigeration efficiency and lead to malfunction

NOTE:- Serving height for children up to 12 years of age.
This model is available with a work top height of 800mm and a Trayslide height of 773mm.
Please add "B" to the end of the product code.

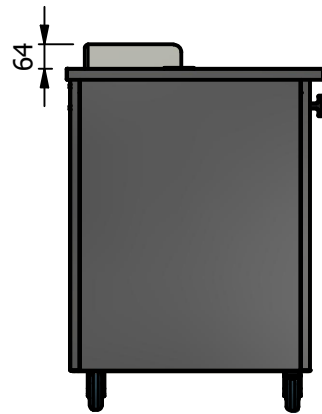
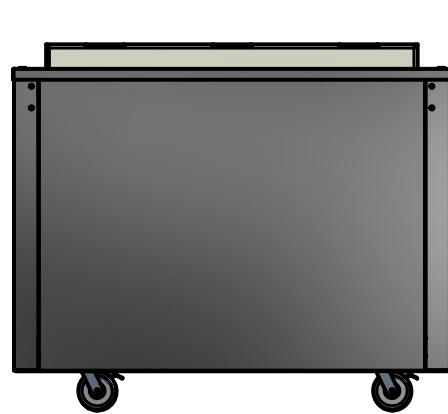
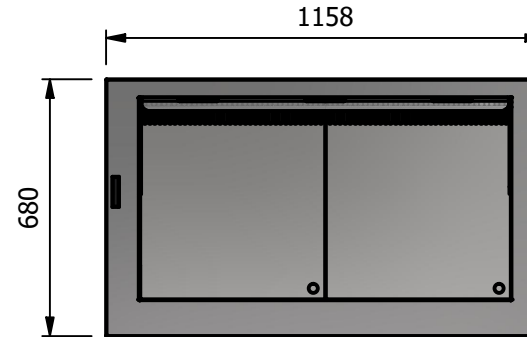
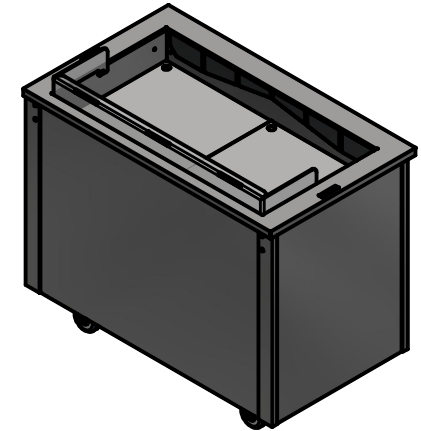

Perspex front screen

Warning
A clear space
of 600mm must
be left at the rear

<<AirFlow
AirFlow>>

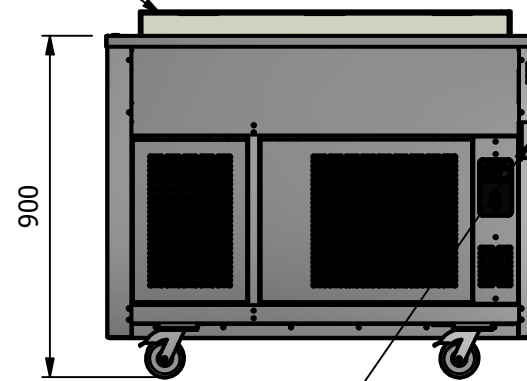

POWER CABLE
ENTRY POINT

Moffat Specification

Dimensions

Width - 1158mm
Depth - 680mm
Height - 900mm
Weight - 125kg
Well - 984mm x 535mm x 130mm

Power Rating

1.2kw
complete with a 2m long cord set & 13amp plug

Materials

0.7mm 430 Grade St/Steel Gantry Hood
1.2mm 304 Grade St/ Steel Top & Supports
1.2mm 430 Grade St Steel Ancillary Parts
6mm Tempered Glass
LED Illumination

Installation

All swivel castors, two braked

ALL SHEET METAL DIMENSIONS ARE I/S (INSIDE SIZES) (UNLESS OTHERWISE STATED)

ALL DIMENSIONS IN (mm), TOLERANCE = LINEAR ± 0.5mm, ANGULAR ± 0.5mm (OR AS STATED). ALL SHARP EDGES TO BE REMOVED FROM SHEET METAL PARTS

Product	VERSICARTE			Product No							
Description	*** VC3RWNG ***										
Material/Finish	Thickness			Desp/Date							
Legacy P/N	Weight	125kg		Quote No.							
Client				SO Number	STANDARD		Drawn By	ABB			
Client Project				Approved By			Date	04/07/2023			
E & R MOFFAT LTD, SEABEGS ROAD, BONNYBRIDGE, FK4 2BS, T: +44 (0)1324 812272, E: sales@ermoffat.co.uk, Web: www.ermoffat.co.uk							Scale	1 : 20	Sheet	1 / 4	A4

No reproduction or publication of this drawing may be made, and no article may be manufactured or assembled in accordance with this drawing without prior written consent. This prohibition is a term of any contract relating to this drawing. Rights reserved under the Copyright Act 1956 as amended by the Design Copyright Act 1968.

