

NOTE:- Serving height for children up to 12 years of age.  
 This model is available with a work top height of 800mm  
 Trayslide height of 773mm.  
 Please add "B" to the end of the product code.

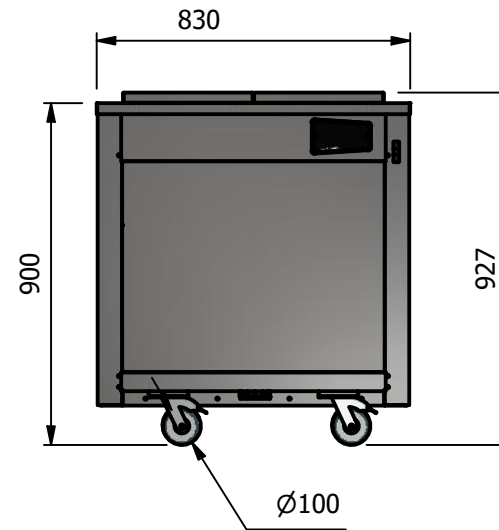
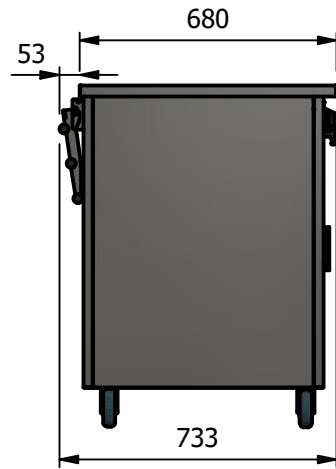
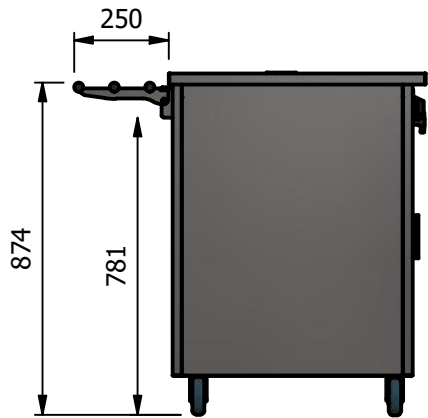
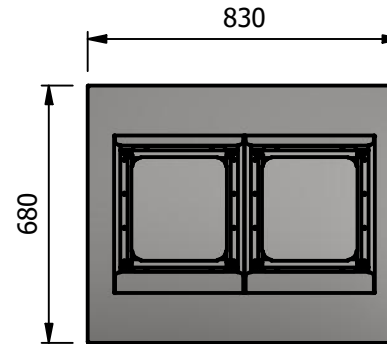

**Moffat Specification**

Fitted with double tube pop up plate dispenser.  
 Designed for the storage and dispensing of any size or shape of plate, be it round, oval, square or designer shape, that can fit within a 305mm (12") square.

Dimensions  
 Width - 830mm  
 Depth - 680mm  
 Height - 927mm  
 Weight - 52kg

Materials  
 1.2mm 304 Grade St/ Steel Top & Supports  
 0.7mm 430 Grade St/ Steel Internal Structure

Installation  
 All swivel castors, two braked

ALL SHEET METAL DIMENSIONS ARE I/S (INSIDE SIZES) (UNLESS OTHERWISE STATED)

ALL DIMENSIONS IN (mm), TOLERANCE = LINEAR ± 0.5mm, ANGULAR ± 0.5mm (OR AS STATED). ALL SHARP EDGES TO BE REMOVED FROM SHEET METAL PARTS

Product	VERSICARTE			Product No	N/A			 The Catering Equipment Company			
Description	*** VC2CDA ***										
Material/Finish	Thickness			Desp/Date							
Legacy P/N	Weight	52kg		Quote No.	Dwg No.	VCP-071146	Issue				
Client				SO Number	STANDARD		Drawn By	ABB			
Client Project				Approved By			Date	28/10/2019			
E & R MOFFAT LTD, SEABEGS ROAD, BONNYBRIDGE, FK4 2BS, T: +44 (0)1324 812272, E: sales@ermoffat.co.uk, Web: www.ermoffat.co.uk							Scale	1 : 20	Sheet	1 / 2	A4

No reproduction or publication of this drawing may be made, and no article may be manufactured or assembled in accordance with this drawing without prior written consent. This prohibition is a term of any contract relating to this drawing. Rights reserved under the Copyright Act 1956 as amended by the Design Copyright Act 1968.