

Optional Tray Slide - Code V1TS

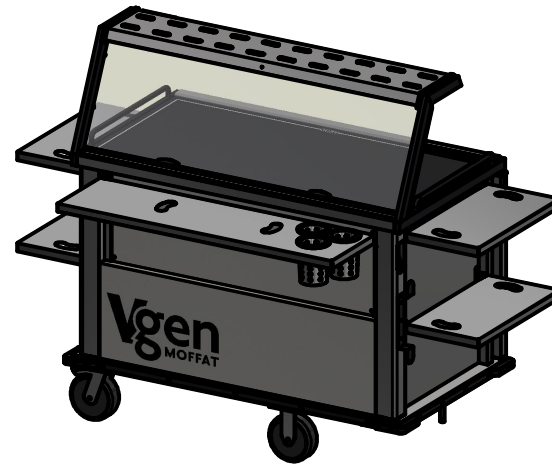
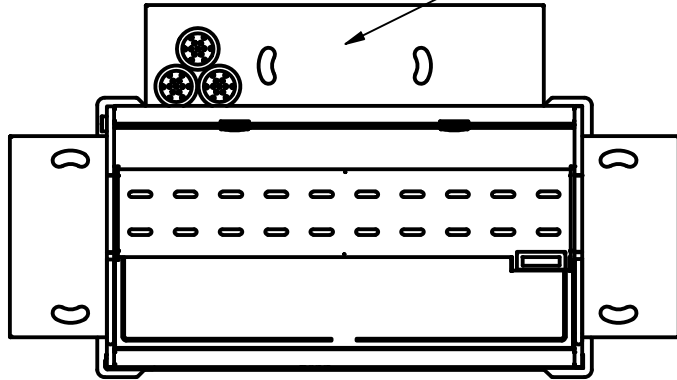

**Moffat Specification**

Dimensions

Width - 740mm  
 Depth - 1308mm  
 Height - 1338mm  
 Weight - 170kg

Power Rating Options

V2GR13 - 2.5 kw 13 amp 1PH  
 V2GR16 - 2.5 kw 16 amp 1PH  
 V2GR163 - 3.75 kw 16 amp 3PH  
 V2GR323 - 3.75 kw 32 amp 3PH  
 complete with a 2m long cord set & plug.

Materials

1.2mm 304 & 430 Grade St/ Steel Top & Supports.  
 0.7 & 1.2mm 430 Grade St Steel Ancillary Parts.  
 Plastic Coated Steel Front and Side panels.  
 1.0mm Aluminium Inner Structure.  
 6mm Perspex Full Front Screen.  
 Neo-Ceram Hot Top Area 1210mm x 590mm.  
 LED Illumination.  
 Fully Insulated Compartment.

Mobility

Castors :- 2 Swivel Type With Brakes, 2 Fixed Direction

Control

Fully Programmably For 24/7 Operation.  
 Three Set Meal Programmes With  
 Boost, Hold, Pre heat, & Cleaning Functions.

Oven

Capacity 98lites  
 8off Gn1/1 Grid shelf positions @ 71mm pitch

Fridge

Capacity 98lites  
 8off Gn1/1 Grid shelf positions @ 71mm pitch

Optional End Shelves Code - VES

Optional End Shelf With Waste Bag Operators Right hand - Code VWR

Optional End Shelf With Waste Bag Operators Left hand - Code VWL

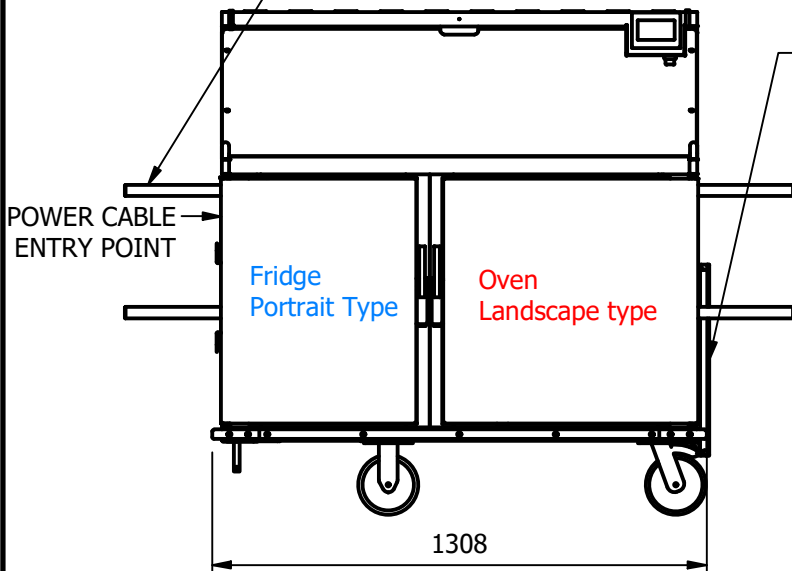

Optional Tow Bar and Hitch Code - VTB

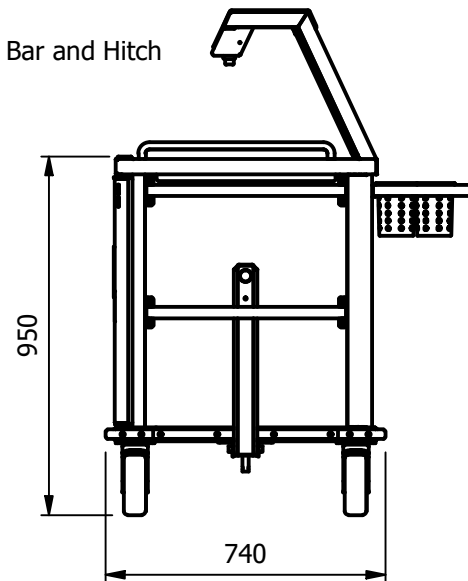

ALL SHEET METAL DIMENSIONS ARE I/S (INSIDE SIZES) (UNLESS OTHERWISE STATED)

ALL DIMENSIONS IN (mm), TOLERANCE = LINEAR ± 0.5mm, ANGULAR ± 0.5mm (OR AS STATED). ALL SHARP EDGES TO BE REMOVED FROM SHEET METAL PARTS

Product	Vgen 2018			Product No		 The Catering Equipment Company
Description	V2GR					
Material/Finish	Thickness		Desp/Date			
Legacy P/N	Weight	170kg	Quote No.		Dwg No.	VGEN-005046
Client			SO Number	N/A	Drawn By	ABB
Client Project			Approved By		Date	22/05/2018
E & R MOFFAT LTD, SEABEGS ROAD, BONNYBRIDGE, FK4 2BS, T: +44 (0)1324 812272, E: sales@ermoffat.co.uk, Web: www.ermoffat.co.uk					Scale	1 : 20
					Sheet	1 / 5
						<b>A4</b>