

Optional Tray Slide - Code V2TS



Moffat Specification

Dimensions

Width - 740mm
 Depth - 1308mm
 Height - 1338mm
 Weight - 175kg

Power Rating Options

V2GPR13 - 2.5 kw 13 amp 1PH
 V2GPR16 - 2.5 kw 16 amp 1PH
 V2GPR163 - 3.75 kw 16 amp 3PH
 V2GPR323 - 3.75 kw 32 amp 3PH
 complete with a 2m long cord set & plug.

Materials

1.2mm 304 & 430 Grade St/ Steel Top & Supports.
 0.7 & 1.2mm 430 Grade St Steel Ancillary Parts.
 Plastic Coated Steel Front and Side panels.
 1.0mm Aluminium Inner Structure.
 6mm Perspex Full Front Screen.
 Neo-Ceram Hot Top Area 1210mm x 590mm.
 LED Illumination.
 Fully Insulated Compartment.

Mobility

Castors :- 2 Swivel Type With Brakes, 2 Fixed Direction.

Control

Fully Programmably For 24/7 Operation.
 Three Set Meal Programmes With
 Boost, Hold, Pre heat, & Cleaning Functions.

Oven

Capacity 98litres
 8off Gn1/1 Grid shelf positions @ 71mm pitch

Fridge

Capacity 49litres
 4off Gn1/1 Grid shelf positions @ 71mm pitch

Plate Warmer

Capacity 56 Litres
 Holds 40 plates [9" / 230mm]

Optional End Shelves Code - VES
 Optional End Shelf With Waste Bag Operators Right hand - Code VWR
 Optional End Shelf With Waste Bag Operators Left hand - Code VWL

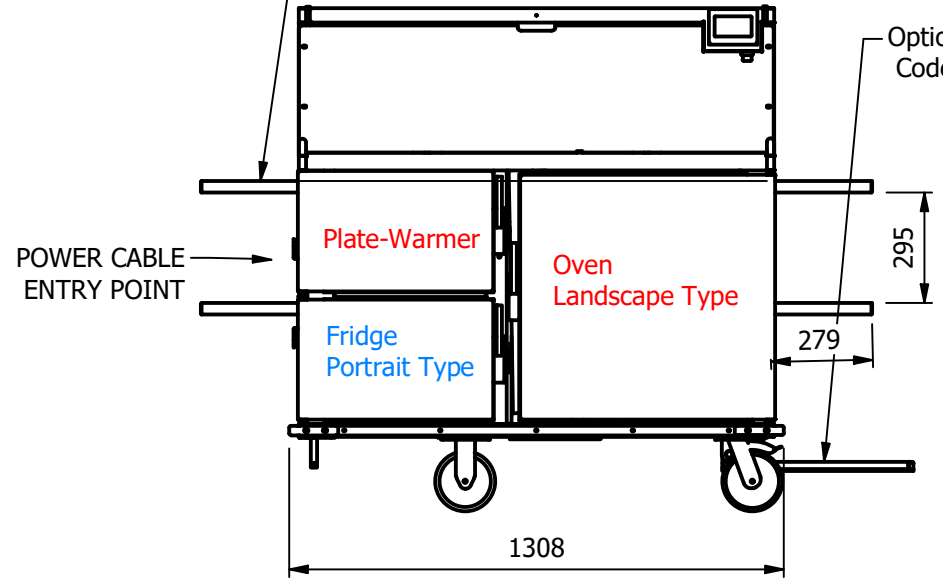

Optional Tow Bar and Hitch Code - VTB

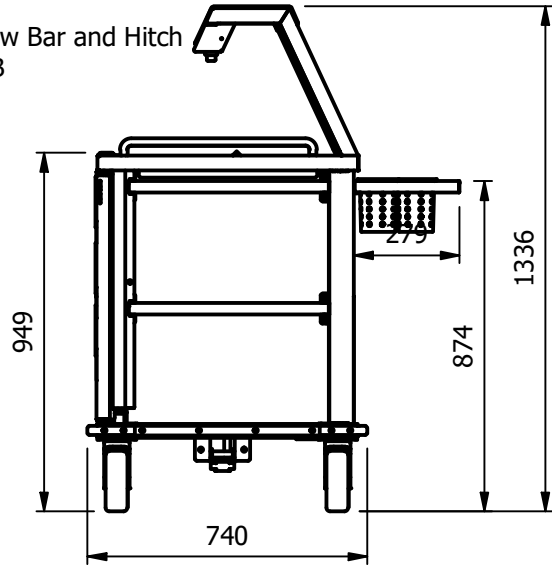

ALL SHEET METAL DIMENSIONS ARE I/S (INSIDE SIZES) (UNLESS OTHERWISE STATED)

ALL DIMENSIONS IN (mm), TOLERANCE = LINEAR ± 0.5mm, ANGULAR ± 0.5mm (OR AS STATED). ALL SHARP EDGES TO BE REMOVED FROM SHEET METAL PARTS

Product	VGEN 2018		Product No		
Description	V2GPR				
Material/Finish	Thickness		Desp/Date		
Legacy P/N	Weight	175kg	Quote No.		
Client			SO Number	N/A	
Client Project			Approved By		
			Dwg No.	VGEN-005383	Issue
			Drawn By	ABB	-
			Date	22/06/2018	
E & R MOFFAT LTD, SEABEGS ROAD, BONNYBRIDGE, FK4 2BS, T: +44 (0)1324 812272, E: sales@ermoffat.co.uk, Web: www.ermoffat.co.uk			Scale	1 : 20	Sheet 1 / 4 A4

No reproduction or publication of this drawing may be made, and no article may be manufactured or assembled in accordance with this drawing without prior written consent. This prohibition is a term of any contract relating to this drawing. Rights reserved under the Copyright Act 1956 as amended by the Design Copyright Act 1968.

