

Optional Tray Slide - Code V2TS

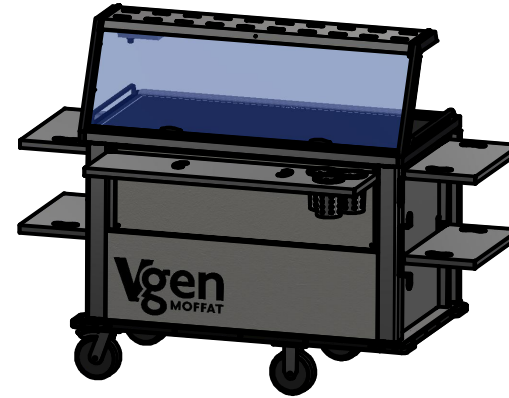

Moffat Specification

Dimensions

Width - 740mm
 Depth - 1308mm
 Height - 1338mm
 Weight - 160kg

Power Rating Options

V2GG13 - 5.0 kw 2 x 13amp 1PH
 V2GG163 - 7.5 kw 1 x 16amp 3Ph
 V2GG323 - 7.5 kw 1 x 32amp 3PH
 complete with a 2m long cord set & plugs.

Materials

1.2mm 304 & 430 Grade St/ Steel Top & Supports.
 0.7 & 1.2mm 430 Grade St Steel Ancillary Parts.
 Plastic Coated Steel Front and Side panels.
 1.0mm Aluminium Inner Structure.
 6mm Perspex Full Front Screen.
 Neo-Ceram Hot Top Area 1210mm x 590mm.
 LED Illumination.
 Fully Insulated Compartment.

Mobility

Castors :- 2 Swivel Type With Brakes, 2 Fixed Direction.

Control

Fully Programmably For 24/7 Operation.
 Three Set Meal Programmes With
 Boost, Hold, Pre heat, & Cleaning Functions.

Oven [2off]

Capacity 98lites
 8off Gn1/1 Grid shelf positions @ 71mm pitch

Optional End Shelves Code - VES
 Optional End Shelf With Waste Bag Operators Right hand - Code VWR
 Optional End Shelf With Waste Bag Operators Left hand - Code VWL

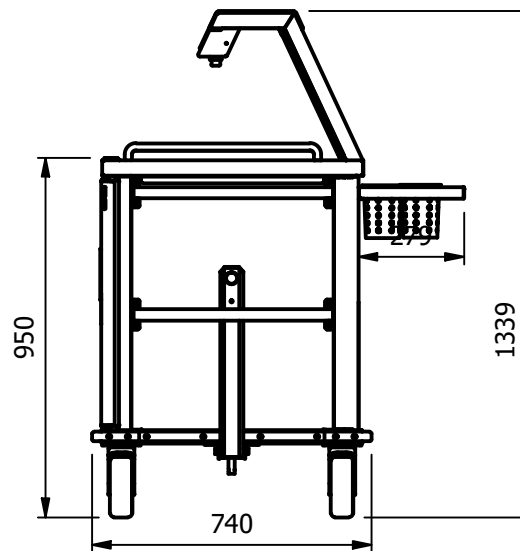
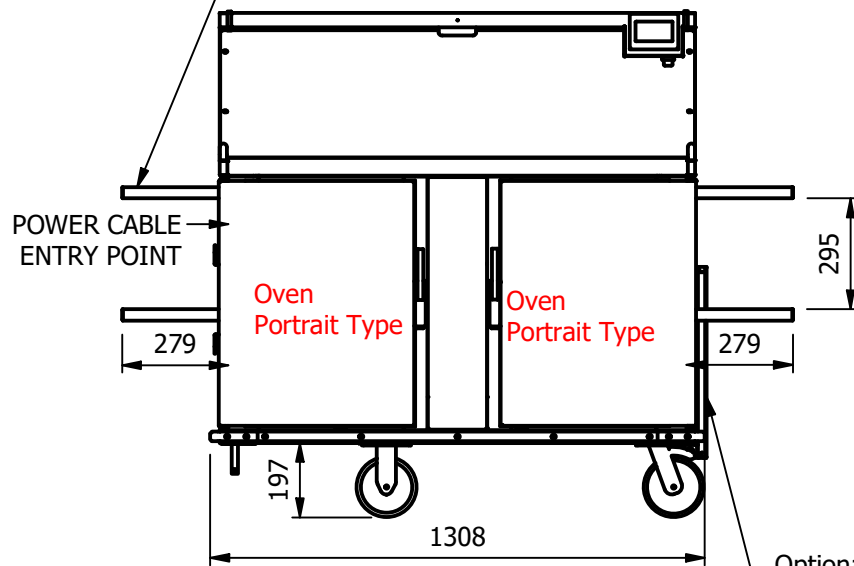

Optional Tow Bar and Hitch
 Code - VTB

ALL SHEET METAL DIMENSIONS ARE I/S (INSIDE SIZES) (UNLESS OTHERWISE STATED)

ALL DIMENSIONS IN (mm), TOLERANCE = LINEAR ± 0.5mm, ANGULAR ± 0.5mm (OR AS STATED). ALL SHARP EDGES TO BE REMOVED FROM SHEET METAL PARTS

Product	VGEN 2018			Product No		 The Catering Equipment Company
Description	V2GG					
Material/Finish	Thickness		Weight	160kg	Desp/Date	
Legacy P/N					Quote No.	
Client					SO Number	N/A
Client Project					Approved By	
E & R MOFFAT LTD, SEABEGS ROAD, BONNYBRIDGE, FK4 2BS, T: +44 (0)1324 812272, E: sales@ermoffat.co.uk, Web: www.ermoffat.co.uk					Dwg No.	VGEN-005601
					Drawn By	ABB
					Date	04/07/2018
					Scale	1 : 28
					Sheet	1 / 3
						A4

No reproduction or publication of this drawing may be made, and no article may be manufactured or assembled in accordance with this drawing without prior written consent. This prohibition is a term of any contract relating to this drawing. Rights reserved under the Copyright Act 1956 as amended by the Design Copyright Act 1968.