

Optional Tray Slide - Code V2TS

Optional end shelves

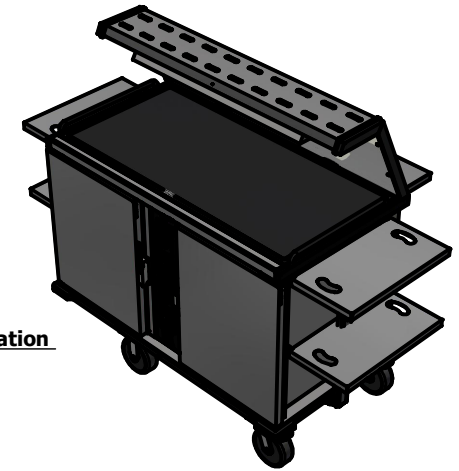
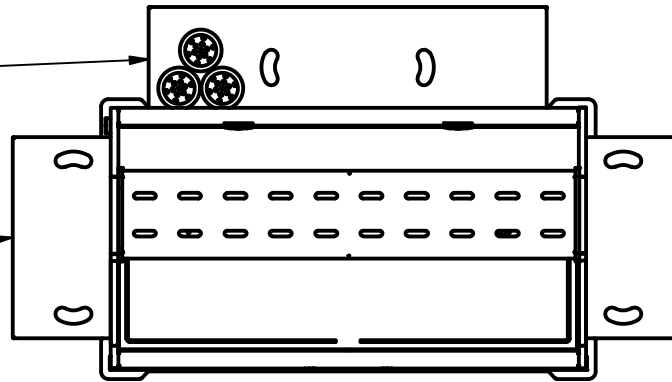

Moffat Specification

Dimensions

Width - 740mm
 Depth - 1308mm
 Height - 1338mm
 Weight - 160kg

Power Rating Options

Model: V2GGE13 - 5.4kw 2 x 13amp 1PH
 Model: V2GGE32 - 5.4kw 1 x 32amp 1PH
 Model: V2GGE163 - 5.4kw 1 x 16amp 3PH
 Model: V2GGE323 - 5.4kw 1 x 32amp 3PH complete with a 2m long cord set & plug.

Materials

1.2mm 304 & 430 Grade St/ Steel Top & Supports.
 0.7 & 1.2mm 430 Grade St Steel Ancillary Parts.
 Plastic Coated Steel Front and Side panels.
 1.0mm Aluminium Inner Structure.
 6mm Perspex Full Front Screen.
 Neo-Ceram Hot Top Area 1210mm x 590mm.
 LED Illumination.
 Fully Insulated Compartment.

Mobility

Castors :- 2 Swivel Type With Brakes, 2 Fixed Direction.

Control

Digital cook time and temperature with automatic keep hot during service

Oven [2off]

Capacity 98 liters
 8off Gn1/1 Grid shelf positions @ 71mm pitch

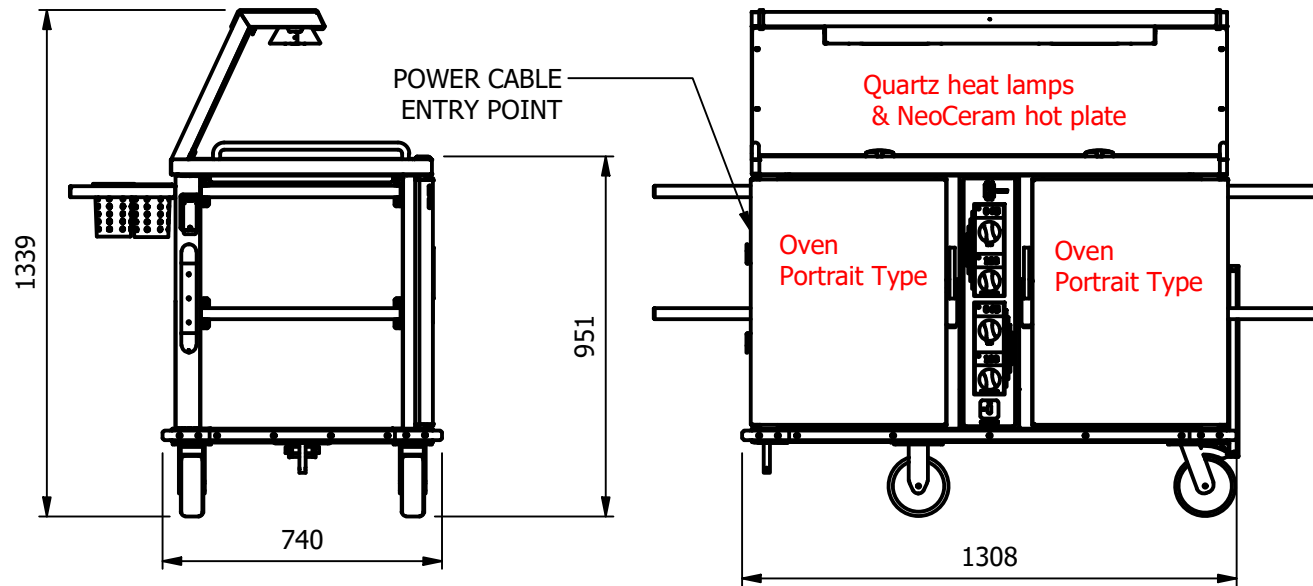

ALL SHEET METAL DIMENSIONS ARE I/S (INSIDE SIZES) (UNLESS OTHERWISE STATED)

ALL DIMENSIONS IN (mm), TOLERANCE = LINEAR ± 0.5mm, ANGULAR ± 0.5mm (OR AS STATED). ALL SHARP EDGES TO BE REMOVED FROM SHEET METAL PARTS

Product	VGEN 2018			Product No							
Description	V2GGE										
Material/Finish	Thickness			Desp/Date							
Legacy P/N	Weight	160kg		Quote No.							
Client				SO Number	N/A		Dwg No.	110717-1	Issue		
Client Project				Approved By			Drawn By	ABB	-		
							Date	04/02/2022			
E & R MOFFAT LTD, SEABEGS ROAD, BONNYBRIDGE, FK4 2BS, T: +44 (0)1324 812272, E: sales@ermoffat.co.uk, Web: www.ermoffat.co.uk							Scale	1 : 20	Sheet	1 / 2	A4

No reproduction or publication of this drawing may be made, and no article may be manufactured or assembled in accordance with this drawing without prior written consent. This prohibition is a term of any contract relating to this drawing. Rights reserved under the Copyright Act 1956 as amended by the Design Copyright Act 1968.