

## Overview

### Cook & Serve

Designed specifically for the education sector where simplicity and easy to use is key. Cooking/regeneration and serving of fresh, chilled or frozen bulk food. This unit allows cook & serve at the point of consumption. Useful for multi-food portioning and multi-food choice. Double oven capacity with unique multi-fan air re-circulation system allows fast and even heat distribution throughout. Complete with an accurately controlled, illuminated self-regulating hot-top.

Designed for GN1/1 type pans, each oven has eight shelves supplied as standard. The oven has a bright, polished, stainless steel interior, satin finished outer panels, complete with a heavy duty hinged doors and slam shut door catches.



### Operating modes:

- **Cook & Serve** - Use in the same manner as a traditional convection oven
- **Cook Chilled** - Regeneration of chilled bulk food [0°C to 8°C optimum 5°C] to above 82°C
- **Cook Frozen** - Regeneration of frozen bulk food [-6°C to -25°C optimum -18°C] to above 82°C
- **Keep Hot** - Holding hot bulk food above 63°C, compartment controlled at 90°C
- **Serve Hot** - Hot-top serving area controlled at 90°C

### Key Features:

- Quartz heat lamps.
- Coloured LED operation indication
- 1/1 GN compatible. Simple to transfer to serving equipment or load from other kitchen appliances
- One-piece, neo-ceram, thermo-panel hot top
- Steam evac & oven door air curtains.
- Digital timer and thermostats guarantee precise time and temperature control.
- Simply rotary controls, temperature and count down timer display, with an audible buzzer indicating when food is ready.
- Multi fans deliver even heating across the entire oven chamber, ensuring no cool spots and consistent cooking results.
- Designed for bulk production, with 8 shelf capacity in each oven (shelf pitch is 71mm)
- Each compartment supplied with removable shelf hangers
- Wide choice of coloured front & end panels (standard colour is Goose Wing Grey)
- Lift-up hob for easy servicing, doors open out 270°, 4 x precision castors, 2 swivel with brakes and 2 fixed

### Benefits:

- Complete with 2m long cable and plug, as standard
- Easy to use
- Automatic Keep hot
- Simply rotary controls, with digital display.
- Easily manoeuvrable, lightweight & compact design.
- high capacity in a small foot print



**Accessories:**

- Fold-down end shelves or optional, recessed end shelf with flip-out waste bag holder
- Fold-down front tray-slide with 3 apertures for cutlery holders
- Gastronorm containers & additional grid shelves
- Tow bar attachment & hitch
- Cassette system in place of the standard shelf hangers with heat retention cover & dolly for transportation

	<b>Oven Capacity</b> (usable space totals 98 liters)	<b>Hot-Top Capacity</b>	<b>Weight of Unit:</b> 120 kg
<b>Width</b>	325 mm	575 mm	
<b>Depth/Length</b>	530 mm	550 mm	
<b>Pitch (per shelf)</b>	71 mm	n/a	
	8 Grid Shelf Positions (8 Supplied)	2 Hot-Top Areas	

**Electrical Specification:**

**Model:** V1GE13

**Rating** -2.7 kw 13amp single phase

**Model:** V1GE16

**Rating** - 5.7 kw 16amp three phase

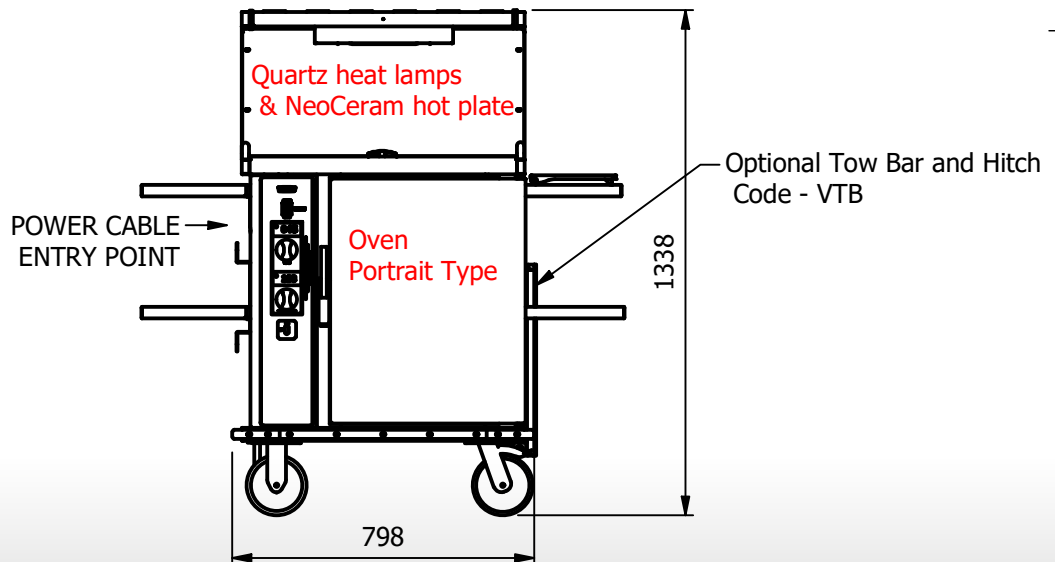
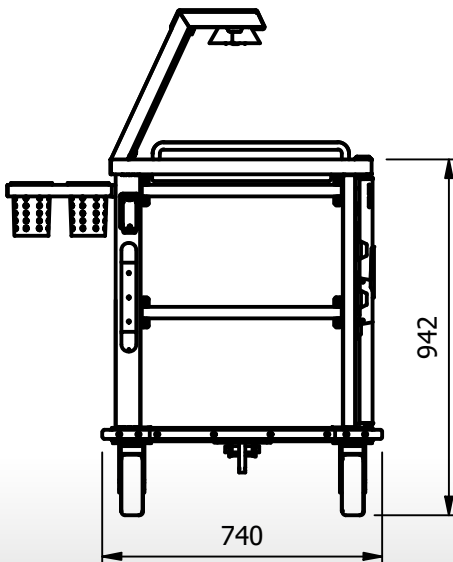

MADE IN BRITAIN

**E&R Moffat Ltd.**  
Bonnybridge  
FK4 2BS  
Scotland



Our blog: [ermoffat.wordpress.com](http://ermoffat.wordpress.com)



[www.ermoffat.co.uk](http://www.ermoffat.co.uk)  
+44 (0) 1324 812272  
[sales@ermoffat.co.uk](mailto:sales@ermoffat.co.uk)