

Moffat Specification

Dimensions
 Width - 740mm
 Depth - 798mm
 Height - 1338mm
 Weight - 120kg

Power Rating
 2.9 kw.
 complete with a 2m long cord set & 13amp plug.

Materials
 1.2mm 304 & 430 Grade St/ Steel Top & Supports.
 0.7 & 1.2mm 430 Grade St Steel Ancillary Parts.
 Plastic Coated Steel Front and Side panels.
 1.0mm Aluminium Inner Structure.
 6mm Perspex Full Front Screen.
 Neo-Ceram Hot Top Area 700mm x 590mm.
 LED Illumination & Quartz heat lamps
 Fully Insulated Compartment.

Mobility
 Castors :- 2 Swivel Type With Brakes, 2 Fixed Direction.

Control
 Digital cook time and temperature
 with automatic keep hot during service

Oven
 Oven Compartment
 Capacity 98litres
 8off Gn1/1 Grid shelf positions @ 71mm pitch

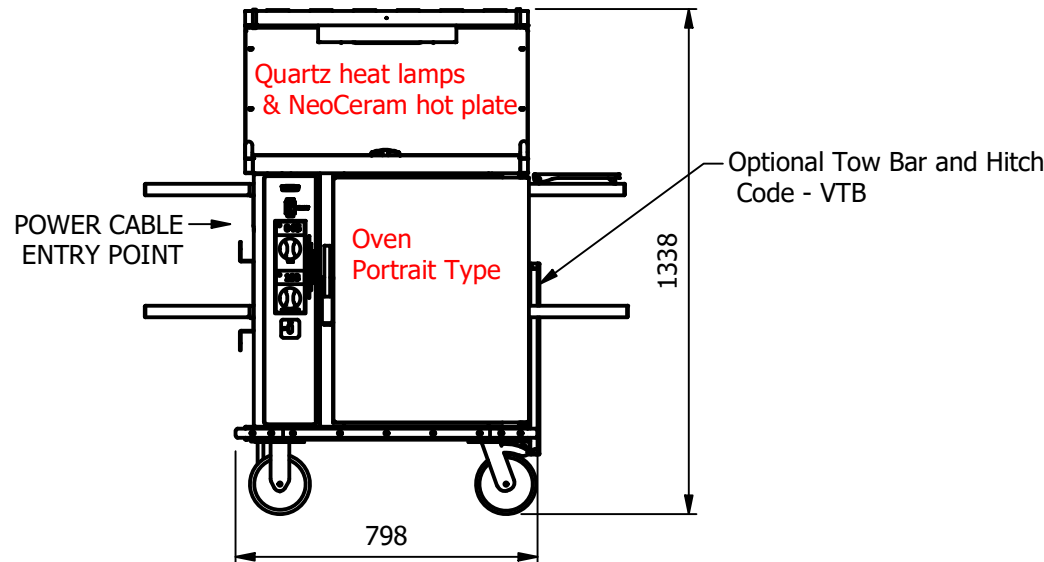
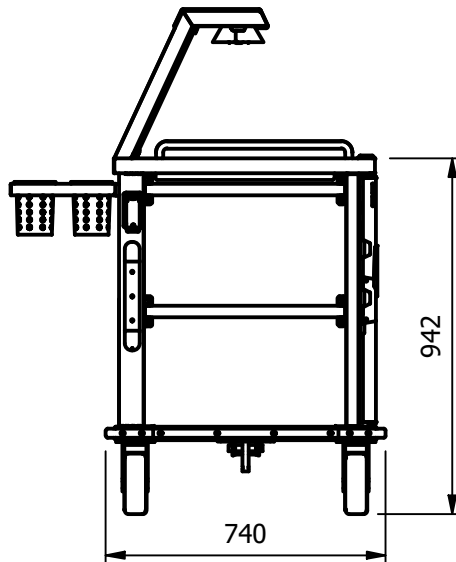

ALL SHEET METAL DIMENSIONS ARE I/S (INSIDE SIZES) (UNLESS OTHERWISE STATED)

ALL DIMENSIONS IN (mm), TOLERANCE = LINEAR ± 0.5mm, ANGULAR ± 0.5mm (OR AS STATED). ALL SHARP EDGES TO BE REMOVED FROM SHEET METAL PARTS

Product	VGEN 2018			Product No			
Description	V1GE			<small>© No reproduction or publication of this drawing may be made, and no article may be manufactured or assembled in accordance with this drawing without prior written consent. This prohibition is a term of any contract relating to this drawing. Rights reserved under the Copyright Act 1956 as amended by the Design Copyright Act 1968.</small>			
Material/Finish	Thickness		Desp/Date				
Legacy P/N	Weight	120kg	Quote No.				
Client			SO Number	N/A	MD No.	156141-1	Issue
Client Project			Approved By		Drawn By	ABB	-
E & R MOFFAT LTD, SEABEGS ROAD, BONNYBRIDGE, FK4 2BS, T: +44 (0)1324 812272, E: sales@ermoffat.co.uk, Web: www.ermoffat.co.uk					Date	11/09/2024	
					Scale	1 : 20	Sheet
							1 / 3
							A4