

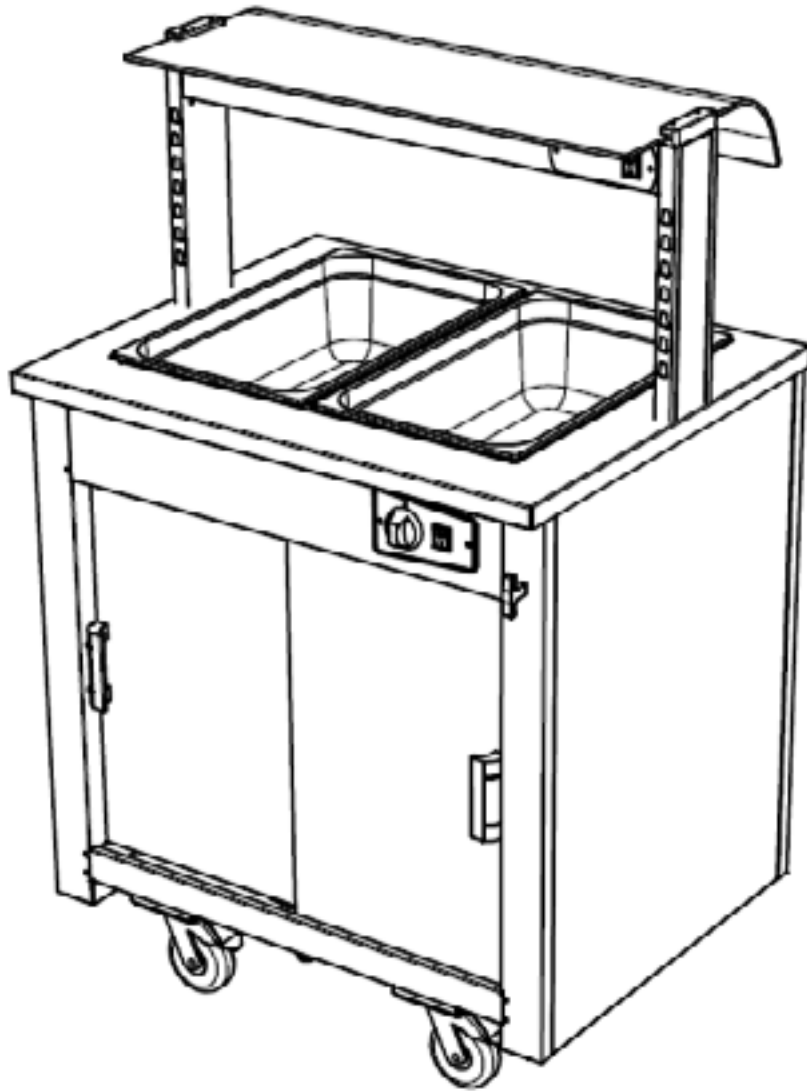

Versicarte-Pro



Operating & Service Manual





To ensure the best results from this unit please take the time to read and follow all safety, installation and maintenance guidelines carefully before proceeding to install. Keep this manual in a safe place for future consultation.



These appliances are marked in compliance with the relevant Low Voltage & EMC Directives. Voltage stated on unit data plate.



Warning!

Please pay attention to sections of the manual displaying this symbol. Do not attempt to use a hose or water jet to clean this unit. For cleaning instructions, refer to section 15.



The appliance must only be used for the purpose it was designed for and may become unsafe if used for any other purpose. Operators should be trained. The room where this trolley is used must be dry, clean with temperatures between 16°C and 25°C and with a maximum relative humidity of 60%. This unit is for indoor use only and has an IPX4 rating.



Warning!

Depending on model, this unit's system may be charged with a flammable refrigerant.

Important points that must be adhered to when using this product.

The position of the appliance must never be altered while connected to the mains power supply.

The mains supply should never be turned off until the power has been turned off on the appliance.

All brakes must be engaged while the appliance is being stored or is in use.

A mains power supply should be made available within 2.5m of where the appliance is being used, never overstretch the power cable.

Multiple units must never be connected to a double 13amp socket. only one appliance should be connected to a double 13amp outlet.

The Bain-marie openings must always be fitted with Gastronorm pans and lids. both during heating up and during service, this is vital to maintain food temps and energy efficiency. Leaving the Bain-marie top open while switched on will place unnecessary stress on the system and may result in integral part failures and service issues.

Contents

		page
1	Electrical Specification	4
2	General Installation	5
3	Refrigerated installation conditions	6 / 7
4	Refrigerated Display and Refrigerated Well Specification & Operation	8 / 9
5	Hot Cupboard Specification & Operation	10 / 11 / 12
6	Hot Top Specification & Operation	13
7	Bain-marie Specification & Operation	14 / 15
8	Heated Display Specification & Operation	16 / 17
9	Soup Station Specification & Operation	18
10	Carvery Station Specification & Operation	19 / 20 / 21
11	Polar Well Specification & Operation	22
12	Plate Dispenser Specification & Operation	23 / 24 / 25 / 26
13	Crockery Dispenser Specification & Operation	27
14	Changing Lights	28
15	Cleaning	29

1: Electrical Specification



This appliance must be earthed and damaged cables must be replaced by a suitably qualified person!

	1 Phase Cable	3 Phase Cable
Live (L1)	Brown	Brown
L2	X	Black
L3	X	Grey
Neutral	Blue	Blue
Earth	Yellow & Green (Striped)	Yellow & Green (Striped)



A mains cable, type H07RN-F, conforming to code designation 60245 IEC 57, is supplied.

“If the supply cord is damaged, it must be replaced by the manufacturer, service agent or suitably qualified person”

Appliance must be disconnected from the power supply during cleaning, maintenance and part-replacement”.

Warning!

Check the 13amp socket is in good condition. Do not use if the plug is a slack fit and slides into the socket easily. Poor contact may cause overheating and failure over time.



Warning!

Do not overload socket. Switch off before inserting or removing the plug. E&R Moffat Ltd. will not accept any responsibility for issues caused by faulty 13amp sockets.

Power Extensions and cables

Power extensions are not recommended, if an extension lead is used beware of the following.

- Never plug more than one appliance into a multi-way adapters / multi-way extension.
- Do not cross a pathway, leads being continually walked over will become damaged.
- Do not allow the cable to become over taut or over-stretched or continually bent.
- Do not allow cables to become tangled. Position carefully preventing risk of tripping.
- Only use an extension lead which was bought ready-assembled.
- Do not use an extension lead that is more than 15 metres long.
- Only use extension leads fitted with suitably insulated connectors and plugs.
- Always check the extension lead plug contains the correctly rated fuse.
- If using a cable drum extension, it should be completely unwound to avoid overheating.

2: General Installation

Before installation please read the following points:

- When placing the counter bodies in position ensure there is adequate access.
- These mobile units can simply be butted up together to form a food service counter.
- Roll into position and apply the brakes on the operator's side.
- Before installing, it is recommended that the floor is swept clean.



This equipment is designed to be operated by suitably qualified persons. It is the responsibility of the Supervisor or equivalent to instruct users, provide suitable P.P.E., show the mains isolating switch location, and inform users that parts may become hot, causing injury if touched.

1. Remove all packaging & plastic coatings from the appliance.
2. Check for any damage.



When removing the stainless steel plastic protection film do not use sharp implements. Extreme care must be taken to avoid scratching the stainless steel surface underneath.

3. Assemble all parts, including shelves, food containers etc.
4. Hot cupboards: Ensure that the heater in the base is located correctly and plugged in.
5. Heated units: Fit the supplied halogen bulbs to the holders under the gantry.
6. Ensure all switches and thermostat controls are in the OFF position.
7. Connect the mains input plug to the socket outlet.
8. Turn on and check the unit is functioning correctly.

3: Refrigeration installation conditions

Refrigerated Unit Venting

When installing these refrigerated units, allowances must be made for air venting.

It is crucial that there is an unrestricted air flow through the under slung compressor and condensing coil. Proper venting must be provided ensuring cool air from the room can be pumped in through the condensing coil and out the other side.

The hot air blown out from the opposite side 'must not' be allowed to be sucked back through.

Refrigerated models
Size 3, 4, and 5.

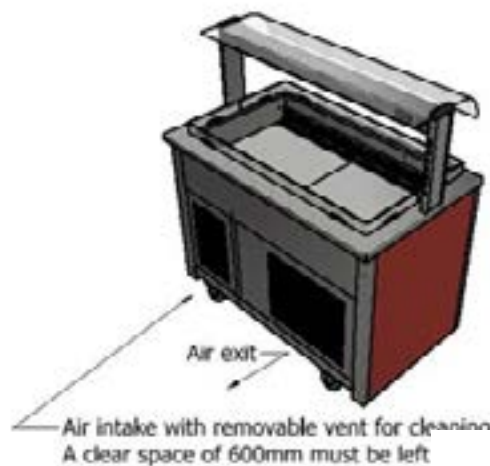

Refrigerated models
with front controls
positioned against a rear wall

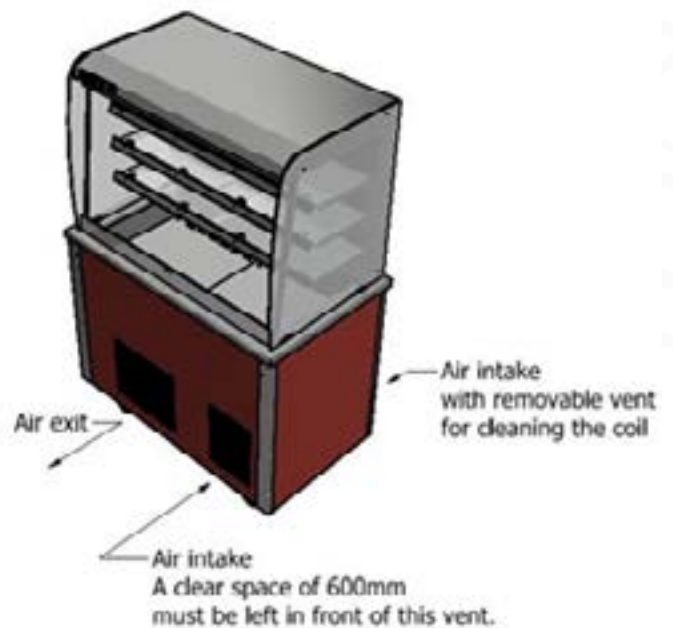

Size 2 refrigerated models

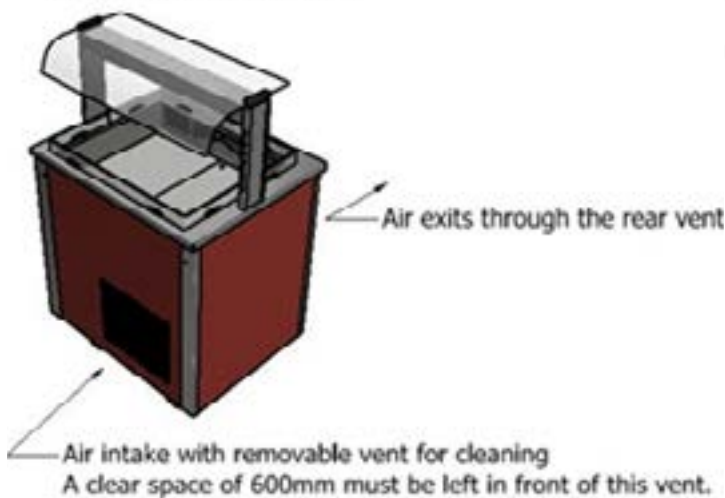

Blocked vents will cause reduced efficiency and lead to malfunction

3: Refrigeration installation conditions



To ensure the satisfactory operation and optimum efficiency of this unit, it is imperative that the ambient room conditions where the units are being used do not exceed a room temperature of 25°C or exceed a relative room humidity of 60%.

Should conditions exceed the above, the display units may not maintain food temperatures at the required levels.

E & R Moffat cannot accept responsibility for the performance of the units being used in extreme conditions.



Do not install units where there is high radiated heat, e.g. direct sunlight, room heaters, or bright spot lights. Do not install units in draughty conditions where the air movement is greater than 0.2mtr/sec. (e.g. near doors, windows, air conditioning units or fans)

The condensing coil & vents requires regular cleaning to maintain the performance of the unit, as air borne particles will choke the coils fins. They should be cleaned with a soft brush and vacuum.

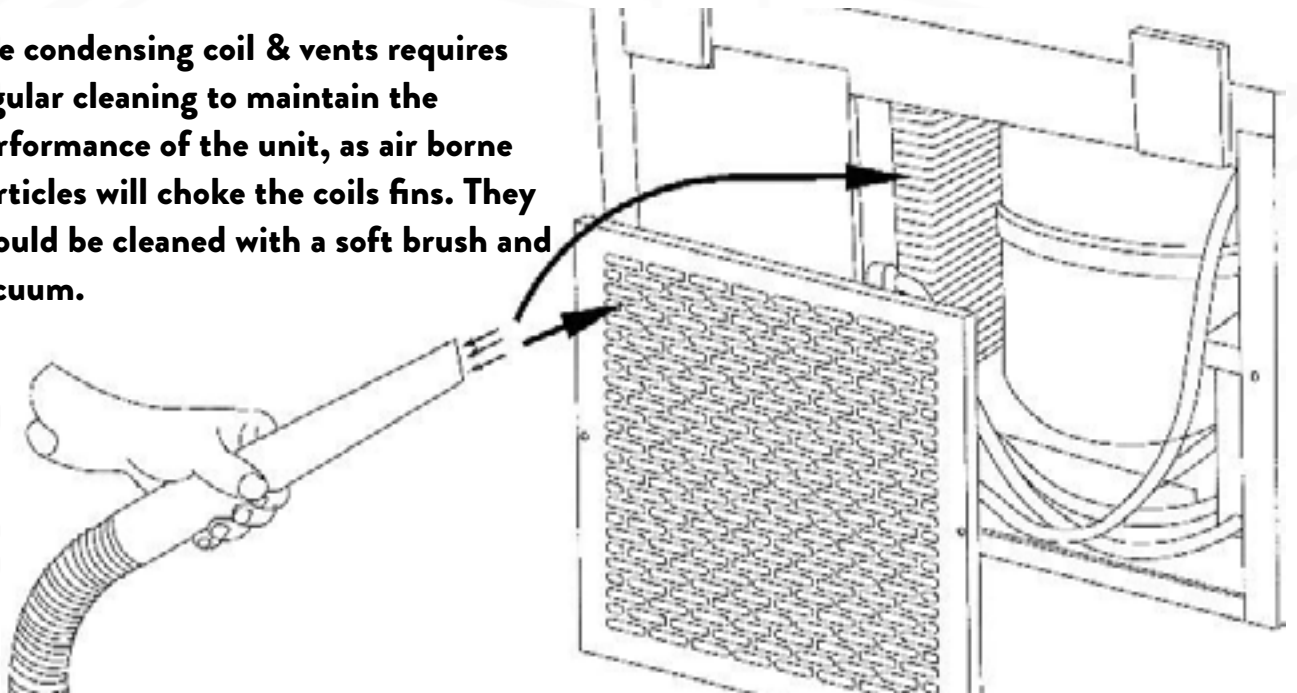

These units require good airflow inside and outside. It is essential the vents in the external panels do not become blocked as this can cause the unit to fail, due to overheating. Internally good air flow must also be maintained, a small space should be left between all products.

4: Refrigeration well specification

Model	Weight (kg)	Dimensions L X W X H (mm)	Electrical Supply	Power Rating (kw)	Power Rating with a gantry
VC2RW	95	830 x 680 x 900	13amp	1.2	1.22
VC3RW	125	1158 x 680 x 900	13amp	1.2	1.23
VC4RW	155	1486 x 680 x 900	13amp	1.2	1.23
VC5RW	185	1814 x 680 x 900	13amp	1.5	1.53

4: Refrigeration display specification

Model	Weight (kg)	Dimensions L X W X H (mm)	Electrical Supply	Power Rating (kw)
VC2RD, VC2RDF, VC2RDFC, VC2RDSL, VC2RDSLFC.	110	830 x 680 x 1650	13amp	1.5
VC3RD, VC3RDF, VC3RDFC, VC3RDSL, VC3RDSLFC, VC3RDSLFC.	150	1158 x 680 x 1650	13amp	1.7
VC4RD, VC4RDF, VC4RDFC, VC4RDSL, VC4RDSLFC, VC4RDSLFC	190	1486 x 680 x 1650	13amp	1.7
VC5RD, VC5RDF, VC5RDFC, VC5RDSL, VC5RDSLFC, VC5RDSLFC	230	1814 x 680 x 1650	13amp	1.7
VC2RDSA, VC2RDSAFC	120	830 x 680 x 1700	13amp	1.5
VC3RDSA, VC3RDSAFC	165	1158 x 680 x 1700	13amp	1.7
VC4RDSA VC4RDSAFC	210	1486 x 680 x 1700	13amp	1.7
VC5RDSA VC5RDSAFC	255	1814 x 680 x 1700	13amp	1.7



This unit's system is charged with a flammable refrigerant (R290).



Before commencing there are certain environmental parameters that must be followed please read the additional installation conditions on page 6 & 7.

4: Refrigeration model operation

Refrigerated display units are designed to keep pre-chilled food at a regulated serving temperature and are suitable for the display of most types of cold food. Designed to provide a gentle flow of cold air maintaining a safe and compliant temperature within. The Chilled display has an automatic defrost, and automatic condensate water evaporation system, eliminating the need to manually empty drip trays or on-site drainage.



The controlled air temperature is factory set to operate between 2° and 5°.

The Display unit is controlled by a green neon on/off switch and a digital control.

- Connect plug to 13-Amp socket and switch on at mains socket.
- Power on with green illuminated Switch
- Digital illuminates and controls the display temperature
- Allow 30mins for the display too cool down before loading product
- The controlled air temperature is factory set to operate between 2° and 5°
- Defrost is factory set to operate automatically when required
- When serving is complete all switches should be turned off.



To enable automatic defrost, the 13A plug must be constantly switched on. The green switch can be switched off when the cooling is no longer required, however, do not un-plug the unit from the mains power.



**Product should already be 5° or below before loaded into the display
These units are not designed to chill down hot food**

5: Hot cupboard

Model	Weight (kg)	Dimensions L X W X H (mm)	Electrical Supply	Power Rating (kw)
VC2HC	34	830 x 680 x 900	13amp	0.9
VC3HC	51	1158 x 680 x 900	13amp	1.5
VC4HC	68	1486 x 680 x 900	13amp	1.5
VC5HC	85	1814 x 680 x 900	13amp	1.9

Hot storage cupboards are designed for preheating Plates & Dishes, as well as the temporary storage of precooked food whilst service is in progress e.g. Cooked meats, poultry, vegetables, sauces, etc. They are heated via a removable 'Sahara' fan heating cell. Fitted with removable sliding doors and removable adjustable for height rod shelves, which are split into manageable sections to ease cleaning and maintenance.



Refer to page 11, for details on how to remove Sahara fan heating cell. for door and shelving adjustment and removal see page 12

The correct Holding temperature is dependent on the food type, amount of food in container, etc. always keep doors closed whenever possible



These units are not designed to heat up cold food.

The Hot cupboard is controlled by green neon on/off switch and a 30° to 110° thermostat control knob.

- Connect plug to 13-Amp socket and switch on at mains socket.
- Power on with green illuminated Switch and turn Control Knob to position 110
- Leave for 15mins to reach serving temperature
- Set the temperature of the Hot cupboard to the desired position
- Dishes can now be loaded.
- When serving is complete all switches should be turned off.
- To maintain the life clean regularly with a damp cloth.



These units will remain hot for a long period of time after use

5: Hot-cupboard

Sahara fan removal & installation



Isolate appliance from power supply & allow to cool down before removal.

The unit can be easily removed & replaced for cleaning or maintenance, due to a simple IEC type fastening system.

- Access to the Plug & socket is via the underside of the unit
- Locate the locking button on the plug and cable push in a pull to release
- Inside the cupboard remove the rod shelf sections to allow access.
- Remove fixing screws and lift out at a slight angle
- Fitting is a reversal of the above.,

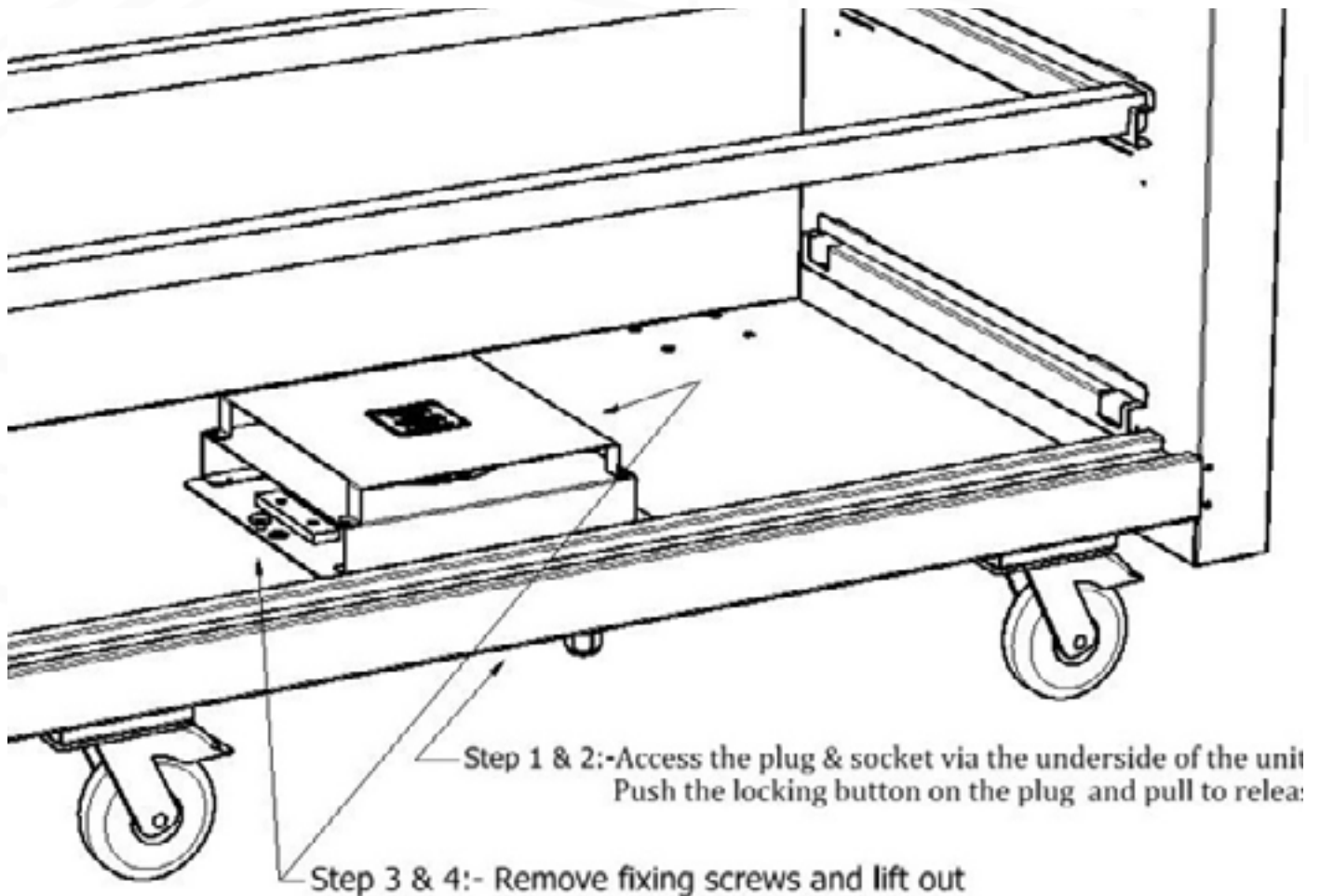

5: Hot-cupboard

Hot Cupboard Doors

Fig 1 demonstrates the fitting of the cupboard doors; in this case, the rear door (Door A).

1. Hold the door at a slight angle & locate the door fully into the top track.
2. Swing the bottom of the door inwards connecting with the bottom track
3. Lower the door into the bottom track, & slide the door fully to the left.

The fitments of the outer door (Door B) is the same as above, except when lowered into the bottom track slide it fully to the right.

Note: It's imperative the doors must be fitted in correct order as shown below - Door 'A' first then Door 'B'

Door removal is a reverse of the above.

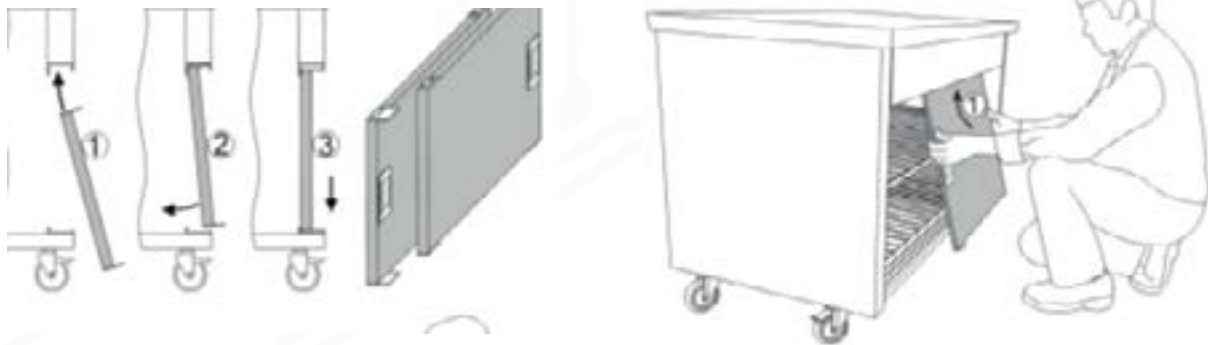

Hot Cupboard shelf removal adjustment

Rod shelving lifts off in easy sections. Shelf support tubes can also be lifted out of the supports and removed.

The side supports can be removed or adjusted for three height positions.

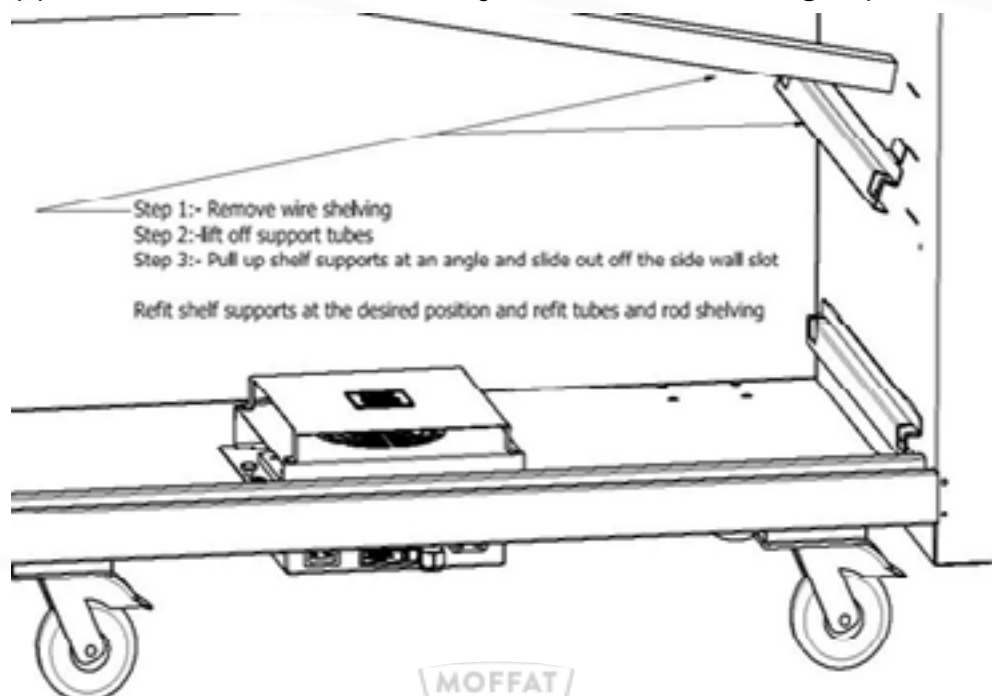

6: Hot Top with hot-cupboard

Model	Weight (kg)	Dimensions L X W X H (mm)	Hot plates (kw)	Fan (kw)	Electrical Supply	Rating (kw)	With Gantry (kw)
VC2HT	55	830 x 680 x 900	2 x 0.18	0.9	13amp	1.26	1.48
VC3HT	82	1158 x 680 x 900	3 x 0.18	1.5	13amp	2.04	2.48
VC4HT	110	1486 x 680 x 900	4 x 0.18	1.5	13amp	2.22	2.88
VC5HT	137	1814 x 680 x 900	5 x 0.18	0.9	13amp	1.80	2.68

Model	Weight (kg)	Dimensions L X W X H (mm)	Top (kw)	Fan (kw)	Electrical Supply	Rating (kw)	With Gantry (kw)
VC2HCS	45	830 x 680 x 900	0.75	0.9	13amp	1.65	1.87
VC3HCS	67	1158 x 680 x 900	1.0	0.9	13amp	1.90	2.34
VC4HCS	90	1486 x 680 x 900	1.0	0.9	13amp	1.90	2.56
VC5HCS	112	1814 x 680 x 900	1.1	0.9	13amp	1.90	2.88

Hot Tops are designed to keep pre-cooked food at serving temperature and are suitable for the display of most types of hot foods. They are fitted with either easy to clean Neo-Ceram thermo panels or a solid stainless steel top with a solid state element under. The self-regulated surface temperature is controlled at around 90°.



These units are not designed to heat up cold food.

The correct serving temperature is dependent on the food type, and quantity. Flat bases dishes are recommended to allow best heat transfer.

The Hot Top & Gantry are both controlled by green neon on/off switches. The hot cupboard is controlled by a 30° to 110° thermostat control knob.

- Connect plug to 13-Amp socket and switch on at mains socket.
- Power on with green illuminated Switch
- Turn Control Knob to position 110
- Leave for 15mins to reach serving temperature
- Set the temperature of the Hot cupboard to the desired position
- Dishes with 'precooked' food can now be loaded.
- When serving is complete all switches should be turned off.
- To maintain the life clean regularly with a damp cloth.



These units will remain hot for a long period of time after use

7: Bain marie (Dry heat) with hot-cupboard

Model	Weight (kg)	Dimensions L X W X H (mm)	Bainmarie (kw)	Fan (kw)	Electrical Supply	Rating (kw)	With Gantry (kw)
VC2BM	45	830 x 680 x 900	0.75	0.9	13amp	1.65	1.87
VC3BM	67	1158 x 680 x 900	1.0	0.9	13amp	1.90	2.34
VC4BM	90	1486 x 680 x 900	1.0	0.9	13amp	1.90	2.56
VC5BM	112	1814 x 680 x 900	1.1	0.9	13amp	2.00	2.88

Bain-marie units are designed to keep pre-cooked food at serving temperature and are suitable for the display of most types of hot foods, complete with an inset well designed to accommodate various combinations of interchangeable Gastronome type pans up to 150 mm deep. Each opening can also be fitted with an optional spiked carvery pad or Neo-Ceram Hot Top adaptor.



These units are not designed to heat up cold food.

The correct serving temperature is dependent on the food type, amount of food in container, etc. Fit empty pans and lids into their openings before switching the unit on. After the 30mins has elapsed load food and replace lids. Do not remove lids until service is due to commence. The Bain-marie & Gantry are both controlled by a green neon on/off switch and a digital temperature control.

- Connect plug to 13-Amp socket and switch on at mains socket
- Power on with green illuminated Switch
- Turn Control Knob to position 110
- Leave for 30mins to reach serving temperature
- Set the temperature of the Bain-marie to the desired position
- Precooked food can now be loaded.
- When serving is complete all switches should be turned off.
- To maintain the life clean regularly with a damp cloth.



These units will remain hot for a long period of time after use

7: Bain marie (Wet / Dry heat) & hot-cupboard

Model	Weight (kg)	Dimensions L X W X H (mm)	Bainmarie (kw)	Fan (kw)	Electrical Supply	Rating (kw)	With Gantry (kw)
VC2BM	51	830 x 680 x 900	2 x 0.75	0.9	13amp	2.40	2.62
VC3BM	75	1158 x 680 x 900	2 x 1.0	0.9	13amp	2.90	3.34
VC4BM	101	1486 x 680 x 900	2 x 1.0	0.9	13amp	2.90	3.56
VC5BM	125	1814 x 680 x 900	2 x 1.0	0.9	13amp	2.90	3.78

This Bain-Marie well can be used either dry or wet heat with an inset well designed to accommodate various combinations of interchangeable gastronome type pans up to 150mm deep. Bain-marie units are designed to keep pre-cooked food at serving temperature and are suitable for the display of most types of hot foods.

 **Wet Heat:**
Water level is an economic, 20mm deep [water level mark on side of well], complete with drain valve and swing-out, run-off tube for easy emptying.

1. First check the drain valve inside the left-hand door of the hot-cupboard is in the closed position.
2. Remove the Bain-Marie container situated at one end. Check the water level mark on the side of the well. (approximately 20mm deep max)
3. Carefully fill well with water up to the water level mark

 **If required top up water level mid service, use suitable heat resistant gloves when removing the hot bainmarie container.**

 **Do not over fill with water. too much water will impinge on performance and efficiency**

4. Replace the container and switch on and Turn Control Knob to position 3 (full on)
5. Turn hot-cupboard control to 110°C.
6. Leave to heat up for approximately 45 minutes before filling containers with food.
7. After 45min set the temperature of the Bain-marie to the desired position
8. Precooked food can now be loaded.

Dry Heat:

Dry heat works in the same way without any water in the well. Heat up time will be around 30 min The base of the well will distort slightly and discolour when used dry. This is normal.

 **These units will remain hot for a long period of time after use**

8: Heated display with storage cupboard

Model	Weight (kg)	Dimensions L X W X H (mm)	Electrical Supply	Power Rating (kw)
VC2HD & VC2HDF	90	830 x 680 x 1650	13amp	1.05
VC3HD & VC3HDF	125	1158 x 680 x 1650	13amp	1.50
VC2HDSL & VC2HDSL	96	830 x 680 x 1655	13amp	1.05
VC3HDL & VC3HDSL	132	1158 x 680 x 1655	13amp	1.50

Designed to keep pre-cooked food at serving temperature and are suitable for the display of most types of hot foods. . Complete with either sliding glass rear doors.



These units are not designed to heat up cold food.

The correct serving temperature is dependent on the food type, quantity and packaging, etc. The Display unit is controlled by a green neon on/off switch and a digital temperature control.

- Connect plug to 13-Amp socket and switch on at mains socket.
- Power on with green illuminated Switch
- Digital illuminates and controls the display temperature
- Leave for 30mins to reach serving temperature
- Set the temperature of the display to the desired position (Factory set at 80° adjustable between 60° and 95°]
- Precooked food can now be loaded.
- When serving is complete all switches should be turned off.
- To maintain the life clean regularly with a damp cloth.



These units will remain hot for a long period of time after use

8: Heated display with storage cupboard

How to Change the Temperature Setting

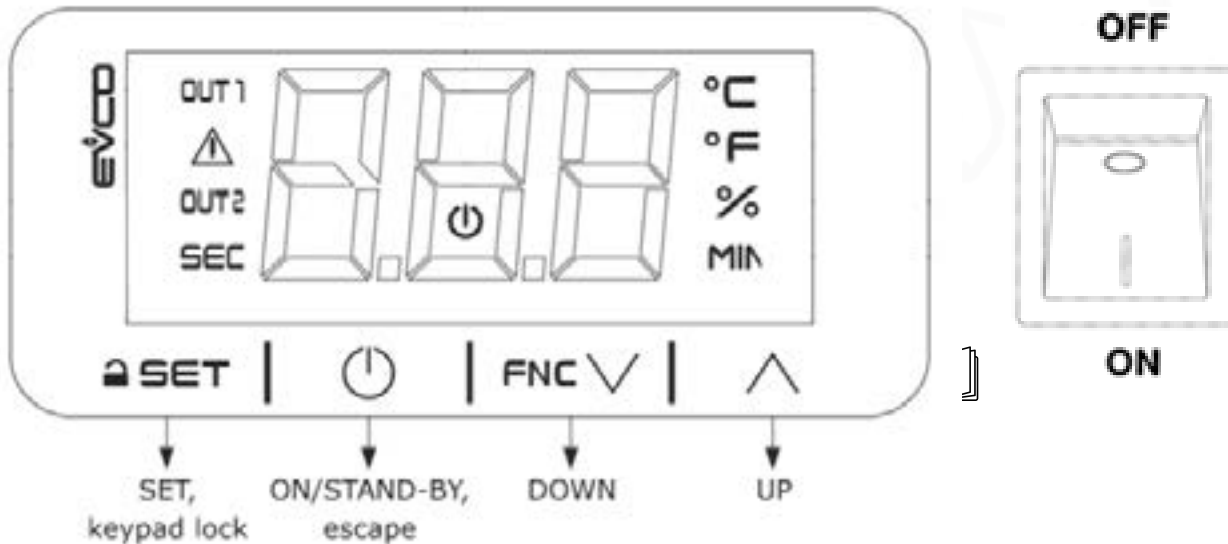

Unlocking the keypad

- Press any button (SET, ON/STAND-BY, DOWN or UP) the display shows **LoC**
- Press and hold the **SET**, keypad lock button for 1 second and the display will show **UnL**.

Setting the temperature setpoint

- Touch the **SET** button and use either the **DOWN** or **UP** buttons to change the set point.
- Once the set point has been chosen, press the **SET** button to confirm, or press the **ON / STAND-BY**, escape button to cancel.

Note

If the **SET** or **ON / STAND-BY**, escape buttons are not pressed within 15 seconds of making a change the action will be cancelled.



- **Hot display units, bain-maries, and hot tops, are designed to hold pre-heated food products at regulated temperatures in an ambient room temperature above 16°C.**
- **Consideration should be made when sighting to avoid positioning close to air conditioning vents, windows and doors where cold draughts may be present. (Food temperature and quality may be affected).**
- **Do not install units in draughty conditions where the air movement is greater than 0.2mtr/sec**

9: Soup station

Model	Weight (kg)	Dimensions L X W X H (mm)	Electrical Supply	Power Rating (kw)
VC2SS	45	830 x 680 x 970	13amp	0.70

These soup kettles are designed to hold 'pre-cooked' soups and gravy at serving temperature

Along with a removable drip tray which aids cleaning, they also come supplied with two 4,5litre stainless steel pots, complete with stainless steel lids.

The correct serving temperature is dependent on the food type / amount etc.

Controls are surface mounted for convenience and consist of a neon power indicator and an energy regulator dial.

- Connect plug to 13-Amp socket and switch on at mains socket.
- Fit empty pans and lids into their openings
- Power on with green illuminated Switch
- Turn control Knob to position No 3
- Leave for 30mins to reach serving temperature
- Set the Knob to the desired position (Position No 3 is full power, Position)
- Precooked Soup can now be loaded.
- Do not remove lids until service is due to commence.
- When serving is complete all switches should be turned off.
- To maintain the life clean regularly with a damp cloth.



These units are not designed to heat up cold food.

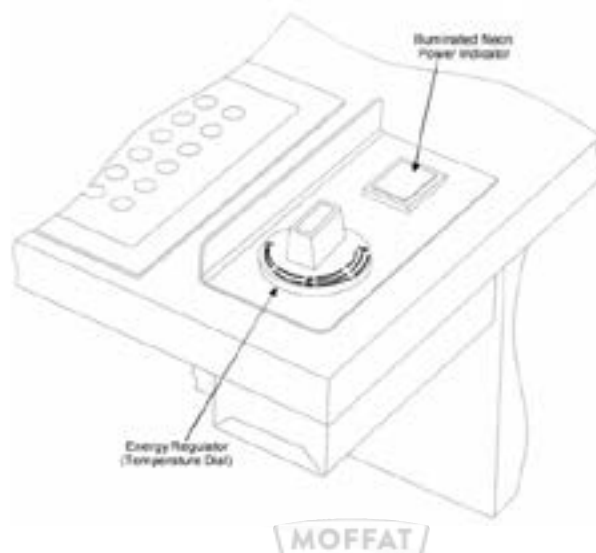

10: Carvery station

Model	Weight (kg)	Dimensions L X W X H (mm)	Bainmarie (kw)	Fan (kw)	Lights (kw)	Electrical Supply	Rating (kw)
VC4CS, VC4CSSL	55	830 x 680 x 900	1.0	0.9	2 x 500	13amp	2.9

A combined Bain-marie, twin carvery pads, and plate dispenser unit, designed to display and hold carvery type food at serving temperature complete with an inset well fitted with GN1/3 and GN1/6 interchangeable Gastronomer type pans, twin spiked carvery pads and a pop up plated dispenser



These units are not designed to heat up cold food.

Fit empty pans and lids and carvery pads into their openings before switching the unit on. After the 30mins has elapsed load food and replace lids. Do not remove lids until service is due to commence.

The Bain-marie & Gantry are both controlled by a green neon on/off switches
The energy efficient Bain-marie and Hot cupboard work in sync, residual heat from the hot cupboard is used to compliment the Bain Marie / Carvery pad heating element.
Hot cupboard & Hot top are controlled by a 30° to 110° thermostat control knob.

- Connect plug to 13-Amp socket and switch on at mains socket.
- Power on with green illuminated Switch
- Turn Control Knob to position 110
- Leave for 60mins to allow plates to reach serving temperature
- Set the temperature of the Control to the desired position
- Precooked food can now be loaded.
- When serving is complete all switches should be turned off.
- To maintain the life clean regularly with a damp cloth.



These units will remain hot for a long period of time after use

10: Carvery station

In-counter spring-loaded pop-up plate dispensers with a variable spring system to accommodate different plate weights. Ideal for oval, round & square crockery including bowls up to 305mm (12"). Each tube can take a maximum of 65 plates (Depending on type of plate used).

Setting the Spring Tension

Plates sits on a removable Plate Base Support which in turn rests on a floating platform. This 'Floating Platform' in turn, is supported by several tension springs. The tension springs are fastened symmetrically on two sides.

In order to access the tension springs the Plate Base Support needs to be removed.

1. Remove lid & store in safe place.
2. Lift out plate/bowl carriage & store in safe place.
3. Unscrew the 4 bolts which secure the two inner panels and remove.
4. Adjust the springs (refer to page 21).
5. Relocate the inner panels. 2 Tabs on the bottom 2 screws on the top of each.

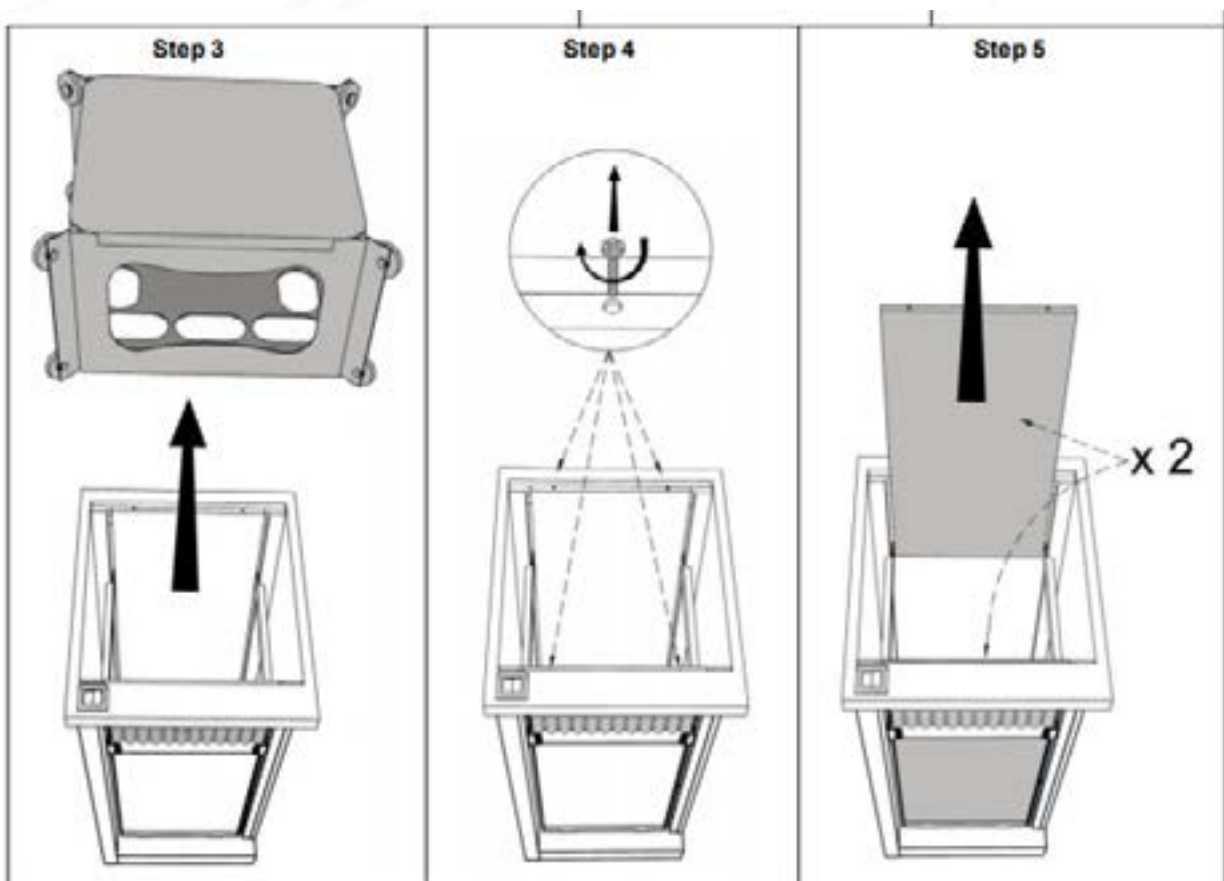

10: Carvery station

The 'Floating Platform' is supported by an equal amount of tension springs on each corner. The number of springs equates to the size of plate being used.

Use the chart below as a starting point; add or remove springs accordingly (in groups of four, one in each corner) until the top plate is at the required level).

The Springs are held in place using a hook & eye arrangement top & bottom. They can be easily attached or detached by just hooking or unhooking the end in to or out of the corresponding hole on the Floating support Arm.

Plate Diameter	Number of Springs on Each Corner	Total Number of Springs
8" (203mm)	2	8
9" (229mm)	3	12
10" (254mm)	4	16
11" (279mm)	5	20
12" (305mm)	6	24

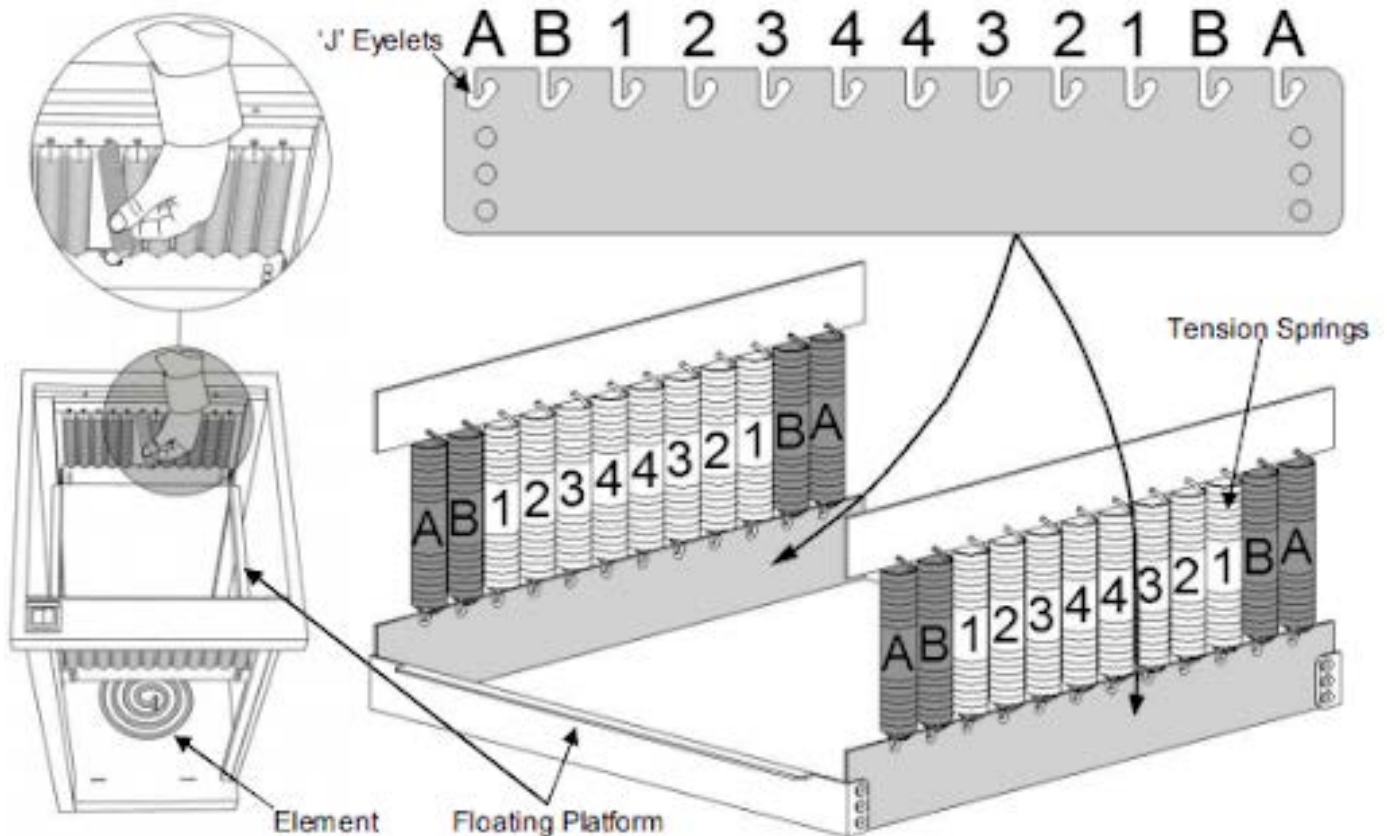

11: Polar Well

Model	Weight (kg)	Dimensions L X W X H (mm)	Electrical Supply	Rating (kw)	With Gantry (kw)
VC2PW	58	830 x 680 x 900	13amp	N/A	0.23
VC3PW	87	1158 x 680 x 900	13amp	N/A	0.27
VC4PW	117	1486 x 680 x 900	13amp	N/A	0.32
VC5PW	145	1814 x 680 x 900	13amp	N/A	0.37

Chilled Polar well display units with ambient storage cupboard.

Polar well models are designed to keep pre-chilled food cold using eutectic type polar plates. Polar plates will keep food chilled for 2 to 3 hours. The polar plates must firstly be charged for 8 to 12 hours in a deep freeze. If longer periods of operation are required extra polar plates can be charged in deep freeze and used in rotation.



Polar Plates weigh 5.5kg and can become slippery when wet.

Care should be taken when handling these units as they contain a liquid refrigerant. The liquid that is sealed inside is free to move around and can make lifting and handling awkward.

The Display unit is controlled by a green neon on/off switch

- Connect plug to 13-Amp socket and switch on at mains socket.
- Power on with green illuminated Switch
- When serving is complete all switches should be turned off.
- To maintain the life clean regularly with a damp cloth.



12: Plate Dispenser

Model	Weight (kg)	Dimensions L X W X H (mm)	Electrical Supply	Rating (kw)
VC2PDH	58	830 x 680 x 1046	13amp	1.20
VC2PDA	57	830 x 680 x 950	N/A	N/A

In-counter spring-loaded pop-up plate dispensers Single or twin plate dispensers, in both ambient & heated formats.

- Adjustable guides to suit 8” - 12” (203mm - 305mm) diameter plates.
- Variable spring system to accommodate different plate weights.
- Each tube can take a maximum of 65 plates (Depending on type of plate used).

Heated Models

- Thermostat controlled internal air temperature approximately 60°
- Complete with ergonomic black ABS plate cover.
- Supplied with a 2-meter cable fitted with a 13-amp molded plug for easy installation.

Operation:

- Load the Tube & cover plates with the supplied black ABS plate cover.
- Switch on the unit using the green switch.
- Allow approximately 60min to warm the plates before serving.
- When serving; remove the top plate & the plate below will automatically pop up.



These units will remain hot for a long period of time after use

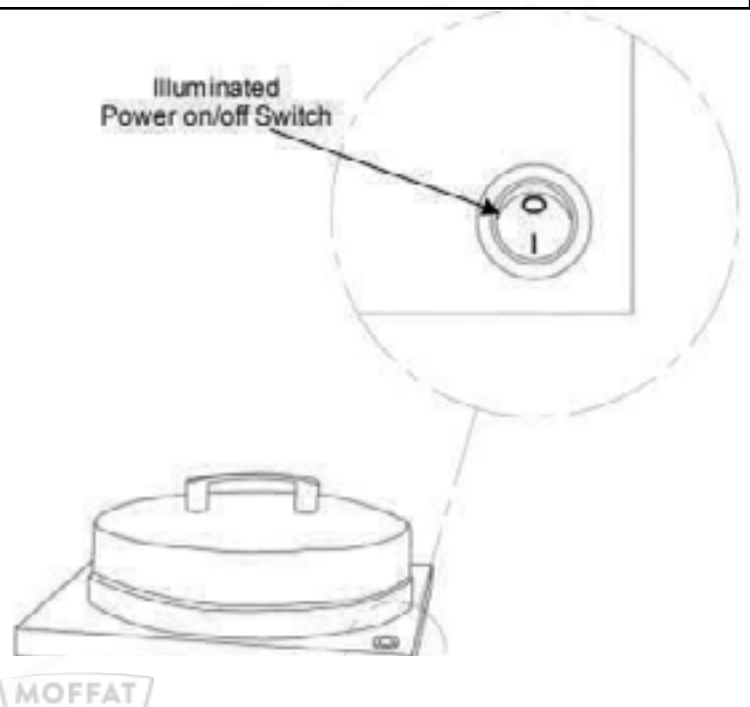

12: Plate Dispenser

Setting the plate diameter by using one plate only,
set the guides to their correct positions for the size of plate.

Plate Diameter	Plate Guide position
8" (203mm)	8
9" (229mm)	9
10" (254mm)	10
11" (279mm)	11
12" (305mm)	12

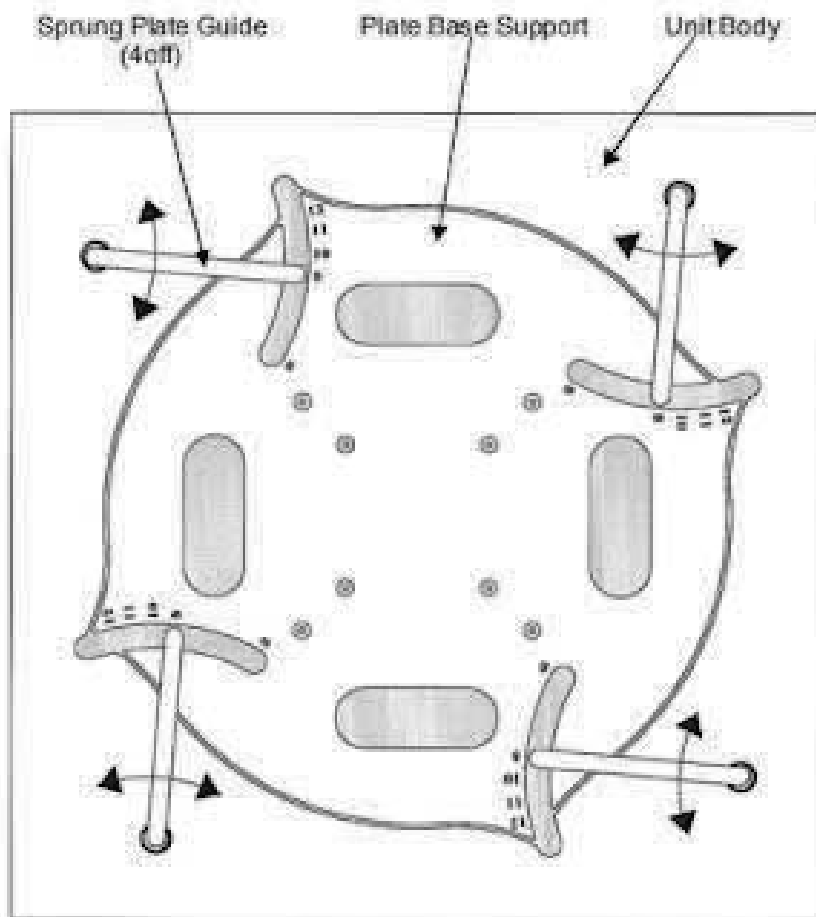

12: Plate Dispenser

Setting the Spring Tension

Plates sit on a removable Plate Base Support which in turn rests on a floating platform.

This 'Floating Platform' in turn, is supported by several tension springs.

The tension springs are fastened symmetrically on two sides.

In order to access the tension springs the Plate Base Support needs to be removed.

1. Pull up the spring loaded 'Plate Guides and swivel anticlockwise to their extreme outer positions & lower down again for them to lock into their 'service' positions.

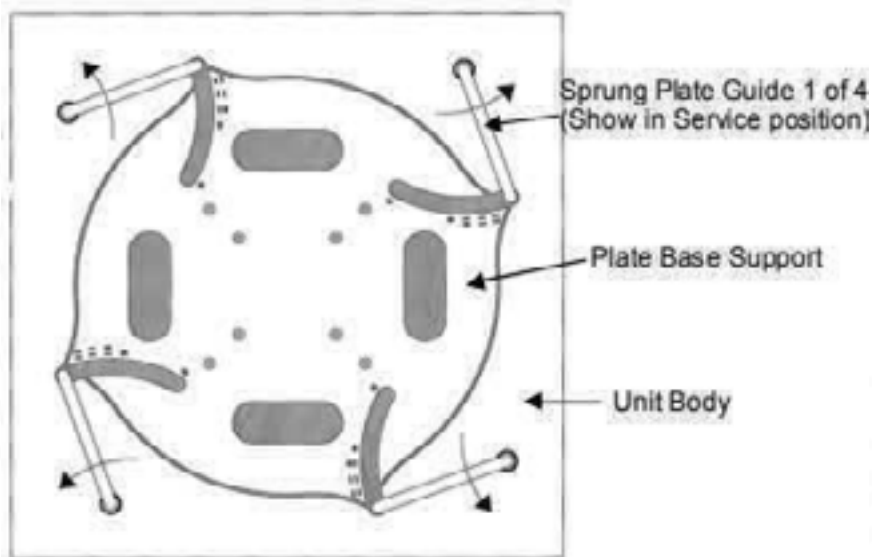

2. Pull up the spring loaded 'Plate Guides and swivel anticlockwise to their extreme outer positions & lower down again for them to lock into their 'service' positions.

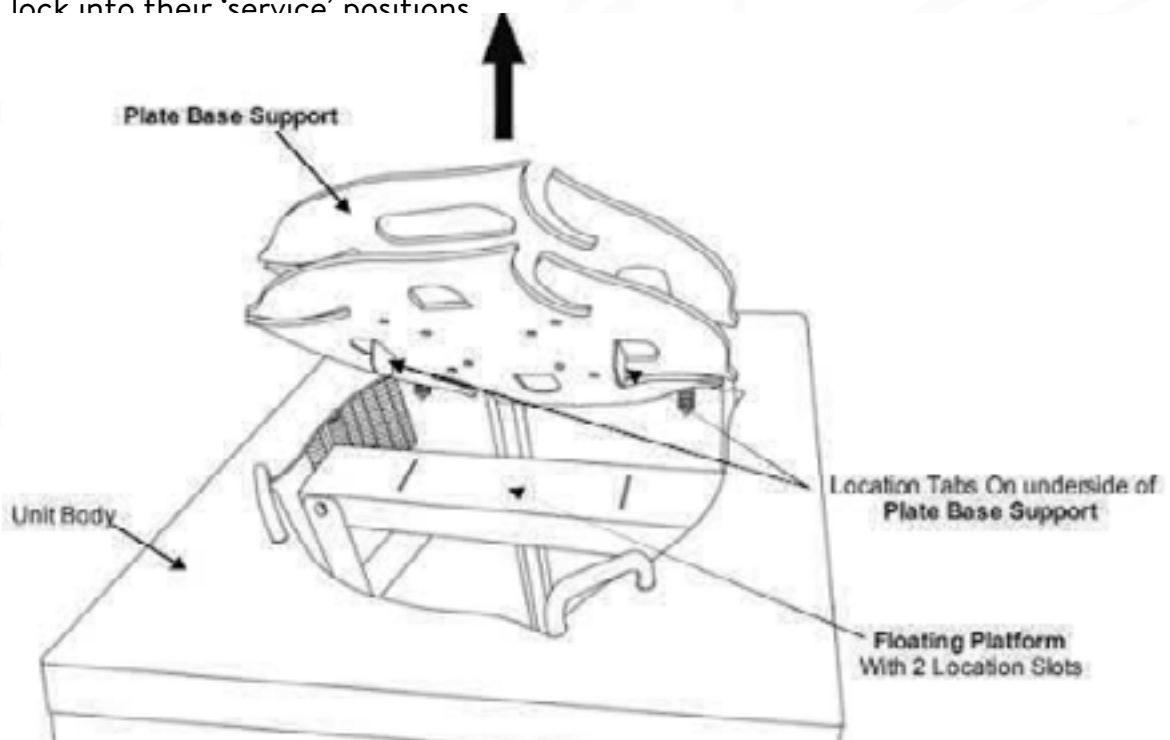

12: Plate Dispenser

3. The 'Floating Platform' is supported by an equal amount of tension springs on each corner.

The number of springs equates to the size of plate being used.

Use the chart below as a starting point; add or remove springs accordingly (in groups of four, one each corner),

until the top plate is at the required serving level)

The Springs are held in place using a hook & eye arrangement top & bottom.

They can be easily attached or detached by just hooking or unhooking the end in to or out of the corresponding hole on the Floating support Arm.



There must be an equal amount of springs on all four corners. The four corner springs should not be removed. When removing springs, start from the centre outwards. When adding springs work from the corners inwards. Keep the spring numbers symmetrical whenever possible.

Plate Diameter	Number of springs on each corner	Total number of springs
8" (203mm)	2	8
9" (229mm)	3	12
10" (254mm)	4	16
11" (279mm)	5	20
12" (305mm)	6	24

Below shows the Plate lift set up for the weight of 9" Plates. Only the 3 outer springs are attached to each corner of the Floating Platform. The 3 inner springs on the left, are shown in their storage position. [hook on top only]

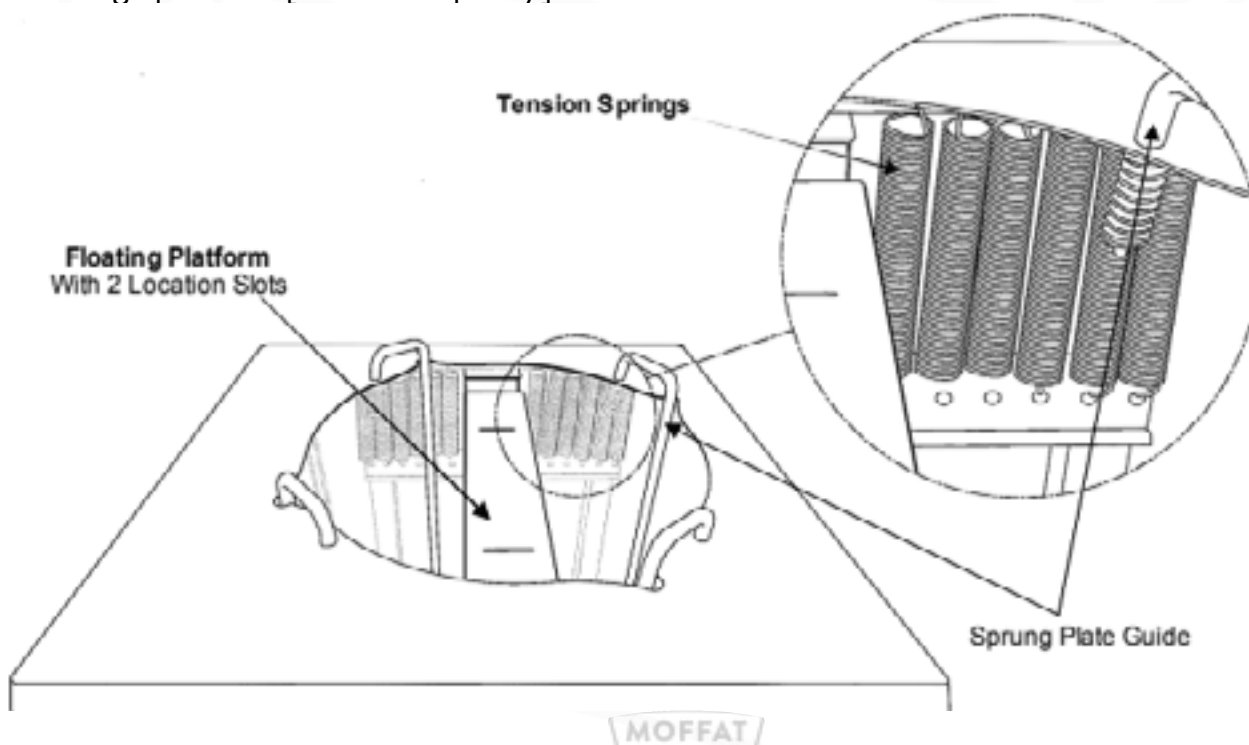

13: Universal Crockery Dispenser

Model	Weight (kg)	Dimensions L X W X H (mm)	Electrical Supply	Rating (kw)
VC2CDH	56	830 x 680 x 939	13amp	1.20
VC2CDA	52	830 x 680 x 930	N/A	N/A

In-counter spring-loaded pop-up plate dispensers. Single tube in both ambient & heated formats. Ideal for oval, round & square crockery including bowls up to 305mm (12"). bowl capacity may be less depending on the type.

- Variable spring system to accommodate different plate weights.
- Each tube can take a maximum of 65 plates
(Depending on type of plate used).

Heated Models

- Thermostat controlled internal air temperature approximately 60°
- Complete with ergonomic stainless steel lid.
- Supplied with a 2-meter cable fitted with a 13-amp molded plug for easy installation.

Operation:

- Load the Tube & cover plates with the supplied stainless steel lid.
- Switch on the unit using the green switch.
- Allow approximately 60min to warm the plates before serving.
- When serving; remove the top plate & the plate below will automatically pop up.

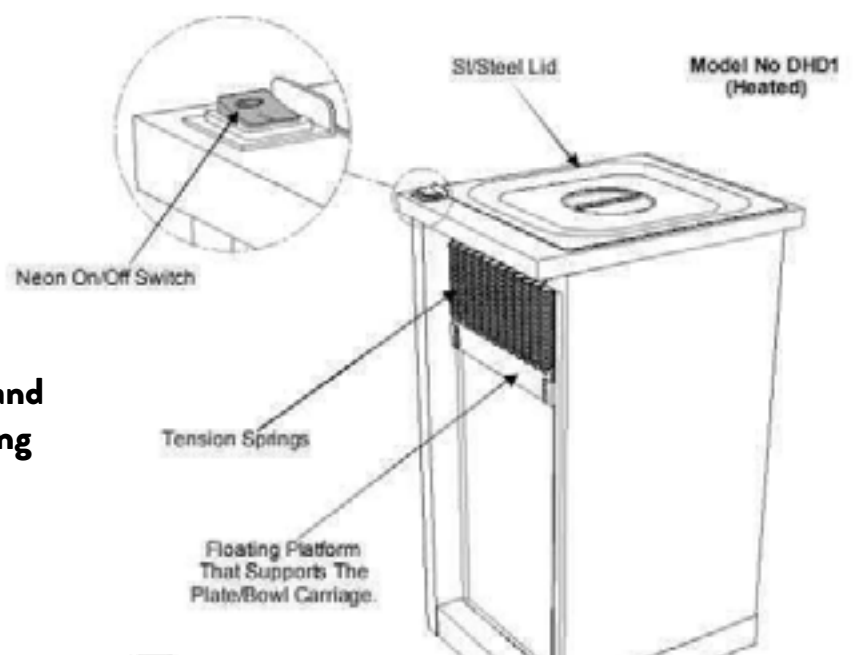

See section 11 on page 20 and 21 for information on setting the spring tension

14: Quartz Lamp Replacement

Ensure appliance is disconnected from mains before servicing.



Lamps should not be touched with bare hands, as this may cause premature failure. If lamp is touched, wipe clean with a cloth and alcohol prior to use.

Replacement quartz lamps must never exceed the loading specified.

Wear safety glasses. Don't touch hot halogen bulbs.

Only use replacement bulbs that match the wattage and design of the fixture.

1. Isolate appliance from power supply and allow cooling down before commencing lamp replacement.
2. Carefully slide mesh guard to one side until it clears the bulb area.
3. Remove faulty lamp by pushing to one side then pull down. Hold the insulated end of the new lamp (Any end).
4. At a slight angle, slot the end of the new lamp into one of the Housing
5. Push against the sprung contact & hold it there.
6. Raise the opposite end of the lamp into the other end of the Lamp.

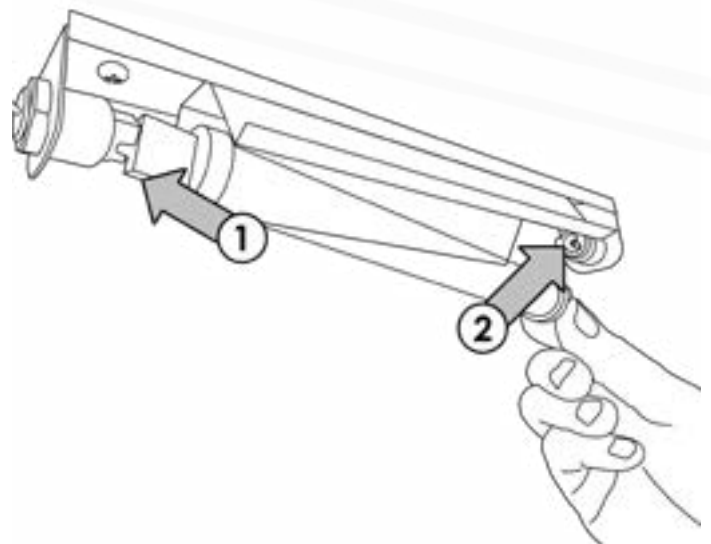
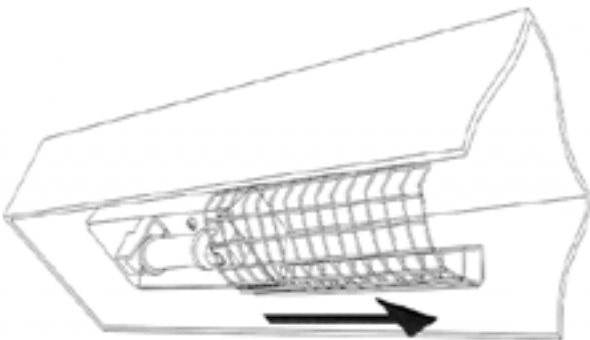

15: Cleaning



Before attempting to clean the unit, please ensure that the Unit is isolated from the electric supply and allowed to cool down, with all food plates and other Dishes removed from the unit.

Do not use a water jet or pressure spray to clean this appliance.

1. Disconnect trolley from mains and wait until appliance has cooled.
2. Wipe clean using hot, soapy water and soft, non-abrasive cloth. Ensure that the stainless steel is wiped in straight strokes following the grain of the material.
3. Wipe dry using a clean cloth. Do not use scouring pads or abrasive cleaners of any type. Shelving and select inner panels can be removed to allow a deeper internal clean. Ensure all panels and fixings are replaced after cleaning operation.
4. Refrigeration compartment should be washed and then dried with a cloth after each service.
5. The chilled well has removable base sections for easy cleaning and maintenance. They should be removed periodically and the area beneath wiped clean.
6. The drain holes must also be kept clear from blockage.
7. Wipe down sneeze screen and glass top with a damp, clean cloth.
8. Finish by carefully drying with a soft dry cloth or Kitchen Towels.



Do not use scouring pads or abrasive cleaners of any type.

Do not use Solvents, bleach, Caustic Cleaners or biological powders on any surface.



Special care should be taken around electrical parts, avoided excessive use of water.

Take special care when cleaning glass use a soft duster & glass cleaner spray.

Thank you for choosing E&R Moffat!

*Scan the QR code below to visit the
E&R Moffat website for further information:*

