

## Overview

Enclosed basket dispenser / warmer, with a Pop-Up variable spring system to accommodate different weights of baskets. Lift off top basket and the next one automatically moves up level into position delivering stacked dishwash type baskets holding different formats and sizes of crockery. This compact mobile unit is perfect for Keeping crockery and plates warm and in one place. Load from the wash-up area & transfer to the point of service. Hygienic design, made of high-quality stainless steel and durable plastic coated outer panels. Four corner bumpers, protect the equipment on all sides. Ergonomically shaped push pull handles ensure optimal handling. Complete with a removable cover the dispenser runs on all-swivel 4" (100mm) casters of which two are lockable.



Model URD

## Key Features:

- Working height set at 890mm from floor level
- Basket Platform: 510 × 510 mm
- Stacking height: 600 mm
- Capacity: 5 baskets (100mm deep)  
7 baskets (75mm deep)
- Four swivel castors two with brakes
- Payload: 100 kg
- Removable cover
- Heating factory set at 40° C
- Simplistic easy adjustable spring system allows repeated pop up plate presentation
- Interior finished in clinical bright polished stainless steel.
- 24/7 operation.
- Exterior panels in durable plastic coated steel



This unit features Moffat's pop-up basket system with a multi-spring, adjustable, floating platform.

Model URD

Length (mm)	Depth (mm)	Height (mm)	Weight (mm)
680	610	890 (1010 with Cover)	40

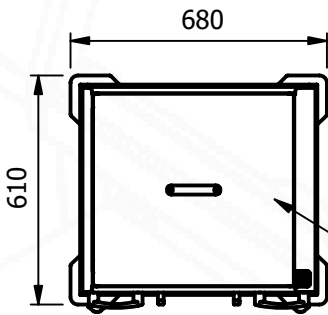

Basket platform 510mm x 510mm

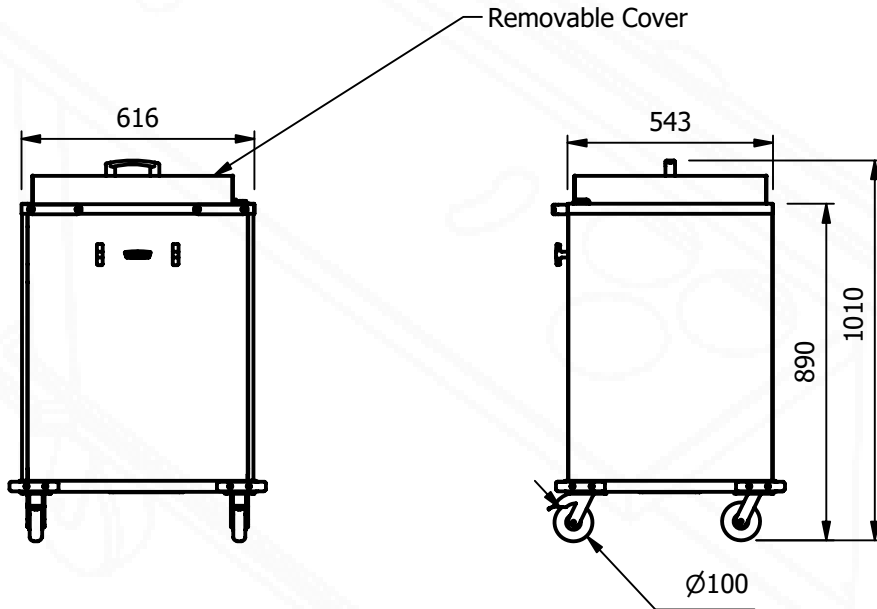

MADE IN BRITAIN

E&R Moffat Ltd.  
Bonnybridge  
FK4 2BS  
Scotland

Find us on:



1963 - 2018

www.ermoffat.co.uk  
+44 (0) 1324 812272  
sales@ermoffat.co.uk