

Basket platform 510mm x 510mm

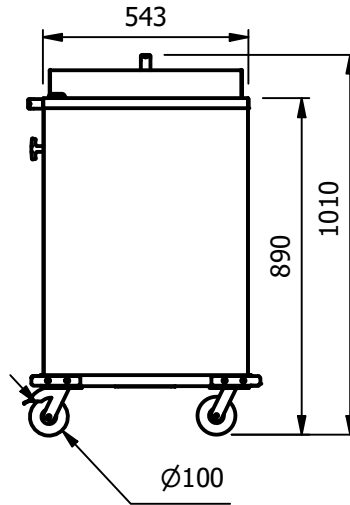

Removable Cover

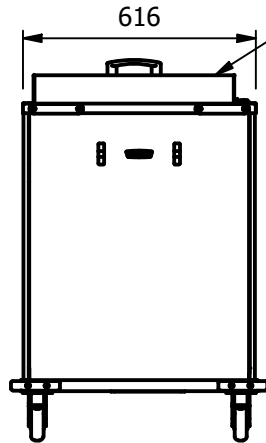

Moffat Specification

Dimensions
 length - 680mm
 Depth - 610mm
 Height - 890mm (1010mm with cover)
 Weight - 40kg

Features
 Basket pickup area 510mm x 510mm

Materials
 2.0mm & 1.2mm 304 & 430 grade St/Steel

Installation
 All swivel castors, two braked

ALL SHEET METAL DIMENSIONS ARE I/S (INSIDE SIZES) (UNLESS OTHERWISE STATED)

ALL DIMENSIONS IN (mm), TOLERANCE = LINEAR ± 0.5mm, ANGULAR ± 0.5mm (OR AS STATED). ALL SHARP EDGES TO BE REMOVED FROM SHEET METAL PARTS

Product	TROLLEYS			Product No	 The Catering Equipment Company
Description	URD				
Material/Finish	Thickness		Desp/Date		<small>No reproduction or publication of this drawing may be made, and no article may be manufactured or assembled in accordance with this drawing without prior written consent. This prohibition is a term of any contract relating to this drawing. Rights reserved under the Copyright Act 1956 as amended by the Design Copyright Act 1968.</small>
Legacy P/N	Weight	40kg	Quote No.	Dwg No.	
Client			SO Number	STD	CTRA-080466
Client Project			Approved By		Issue
E & R MOFFAT LTD, SEABEGS ROAD, BONNYBRIDGE, FK4 2BS, T: +44 (0)1324 812272, E: sales@ermoffat.co.uk, Web: www.ermoffat.co.uk					1 / 2
					Scale
					1 : 20
					Sheet
					A4