

Overview

Pop Up plates system with a multi spring floating platform. Lift off top plate and the next one automatically moves up into position. Designed for the storage and dispensing of any size or shape of plate, be it round, oval, square or designer shape, that can fit within a 305mm (12") square. The heated versions temperature is controlled by an internal thermostat with surface level illuminated on/off switch for easy operation. Heated units also have a Stainless-steel type cover to each tube as standard. With a maximum capacity of around 65 plates per tube. Heated units are also supplied with a moulded 13 amp plug & 2 metre cord for easy installation. [13A 230V]



Key Features:

- Can accommodate multiple stacks of small bowls etc.
- Interior finished in clinical bright polished stainless steel.
- Capacity approximately 65 plates per tube depending on type, profile and thickness.
- Simplistic easy adjustable spring systems allows repeated pop up plate presentation
- 24/7 operation.
- Self-contained unit.
- Mobile all swivel castors two with brakes.

Heated models

- With well proven elements provide evenly distributed heat.
- Factory set thermostat controls internal air at 60° C.
- Complete with stainless steel lid.
- Supplied with a 2-metre-long cord set with moulded 13 amp plug for easy installation.

Options:

- Wide choice of coloured outer panels (Durable plastic coated steel).
- Fold down solid tray slide or tubular tray rail.
- Stainless steel lid for VC2PDA model

Note:

Low height models are available set at 800mm high. Ideal for children up to 12 years. These low height models have a "B" added to the model code.

Optional solid tray slide
Matching size VC2TS

Optional tubular tray rail
Matching size VC2TR

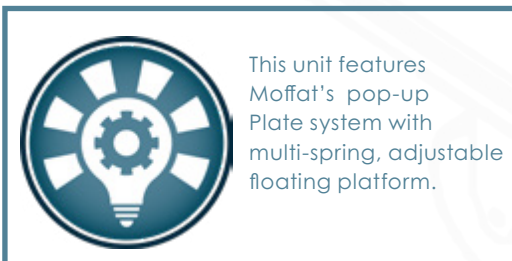
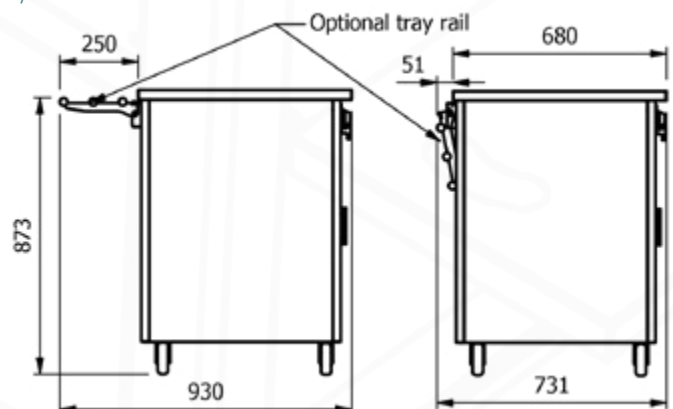



| Model | Capacity | Weight (kg) | L x W x H (mm) | Height above top (mm) | Electrical Supply | Power Rating (kw) |
|--------|----------|-------------|-----------------|-----------------------|-------------------|-------------------|
| VC2CDH | 2 x 65 | 56 | 830 x 680 x 939 | 30 | 13amp | 1.2 |
| VC2CDA | 2 x 65 | 55 | 830 x 680 x 927 | 30 | N/A | N/A |

