

Sliding glass doors on both sides

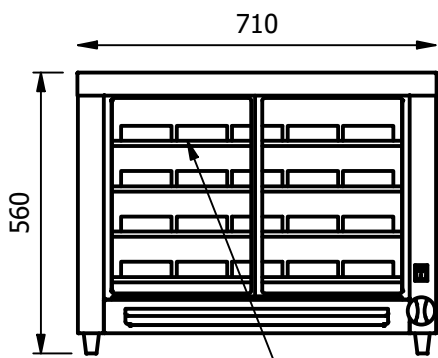

Pull out crumb tray with an internal humidity feature.



Removable and Adjustable shelving

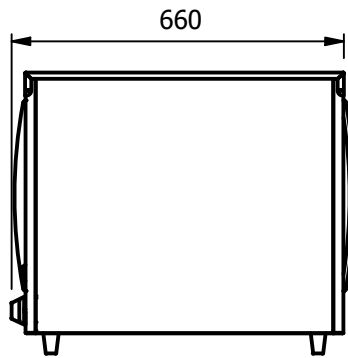

Moffat Specification

Dimensions
 Width - 710mm
 Depth - 660mm
 Height - 560mm
 Weight - 40kg

Capacity
 Cabinet capacity - 126 Litres
 4 removable perforated shelves standard pitch 90mm adjustable in 30mm increments

Power Rating
 1.5kw
 complete with a 2m long cord set & 13amp plug

Materials
 0.7mm 430 Grade St/Steel inner panels
 1.2mm 430 Grade St/ Steel structure
 1.2mm 430 Grade St Steel Ancillary Parts
 Single Glazed Tempered Glass

ALL SHEET METAL DIMENSIONS ARE I/S (INSIDE SIZES) (UNLESS OTHERWISE STATED) ALL DIMENSIONS IN (mm), TOLERANCE = LINEAR ± 0.5mm, ANGULAR ± 0.5mm (OR AS STATED). ALL SHARP EDGES TO BE REMOVED FROM SHEET METAL PARTS

Product	COUNTERS			Product No	PC2			<small>No reproduction or publication of this drawing may be made, and no article may be manufactured or assembled in accordance with this drawing without prior written consent. This prohibition is a term of any contract relating to this drawing. Rights reserved under the Copyright Act 1956 as amended by the Design Copyright Act 1968.</small>	 The Catering Equipment Company
Description	PC2 - PIE CABINET			Desp/Date					
Material/Finish	Thickness			Quote No.			Dwg No.	CTRA-076088	Issue
Legacy P/N	Weight	40kg		SO Number	STD		Drawn By	N.Raymen	-
Client				Approved By			Date	09/07/2020	
Client Project							Scale	1 : 15	Sheet