

Sliding glass doors

Pull out crumb tray with an internal humidity feature.

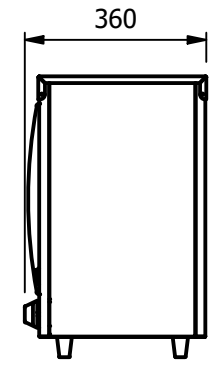
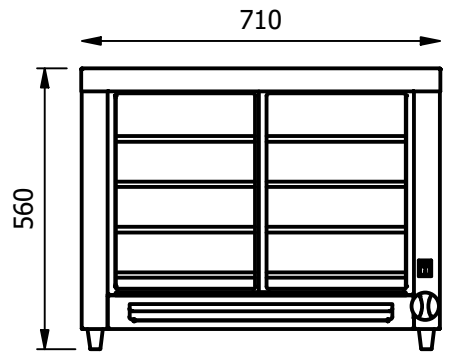
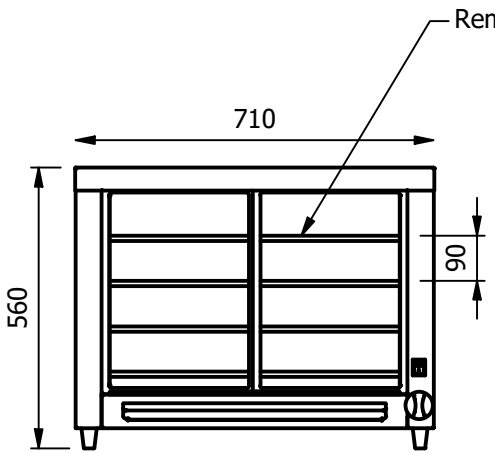

Moffat Specification

Dimensions
 Width - 710mm
 Depth - 360mm
 Height - 560mm
 Weight - 22kg

Capacity
 Cabinet capacity - 61 Litres
 4 removable perforated shelves standard pitch 90mm adjustable in 30mm increments

Power Rating
 0.75kw
 complete with a 2m long cord set & 13amp plug

Materials
 0.7mm 430 Grade St/Steel inner panels
 1.2mm 430 Grade St/ Steel structure
 1.2mm 430 Grade St Steel Ancillary Parts
 Single Glazed Tempered Glass

ALL SHEET METAL DIMENSIONS ARE I/S (INSIDE SIZES) (UNLESS OTHERWISE STATED) ALL DIMENSIONS IN (mm), TOLERANCE = LINEAR ± 0.5mm, ANGULAR ± 0.5mm (OR AS STATED). ALL SHARP EDGES TO BE REMOVED FROM SHEET METAL PARTS

Product	COUNTERS			Product No	PC1		
Description	PC1 - PIE CABINET						 The Catering Equipment Company
Material/Finish	Thickness		Desp/Date				
Legacy P/N	Weight	22kg	Quote No.		Dwg No.	CTRA-076048	
Client			SO Number	STD	Drawn By	N.Raymen	
Client Project			Approved By		Date	09/07/2020	