

Important Design Parameters

Allowances must be made for air venting.

The under slung compressor must have an unrestricted air flow.

Proper venting must be provided ensuring cool air from the room can be drawn in through the condensing coil and out the other side.

Warning

Do not install unit in draughty conditions where the air movement is greater than 0.2mtr/sec.

e.g. near entrance/exit doors, open windows, under air conditioning units or a ceiling mounted fan

Do not install units where there is high radiated heat, e.g. direct sunlight, room heaters, or bright spot lights

Ambient room conditions must not exceed 25°C or a relative humidity of 60%.

Blocked vents will cause reduced refrigeration efficiency and lead to malfunction

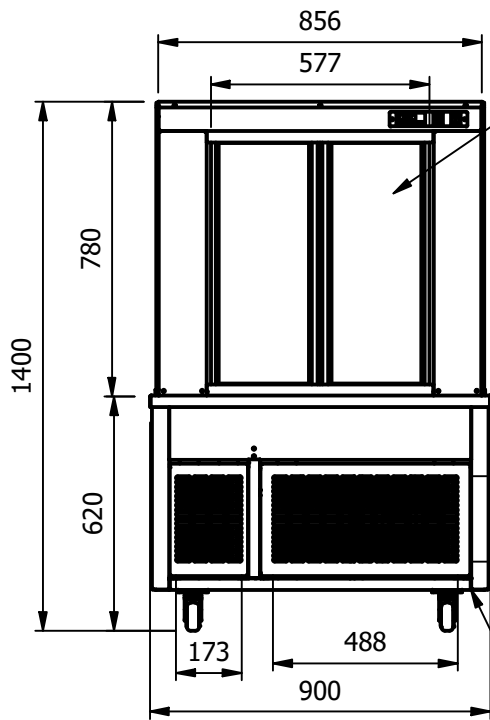
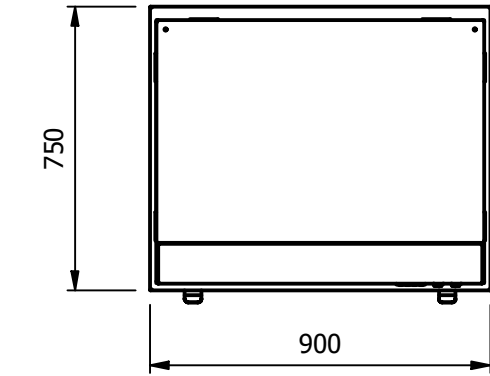
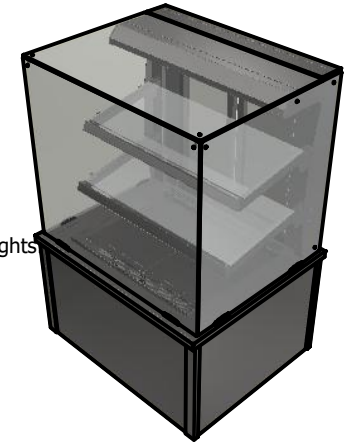

Rear double glazed sliding doors

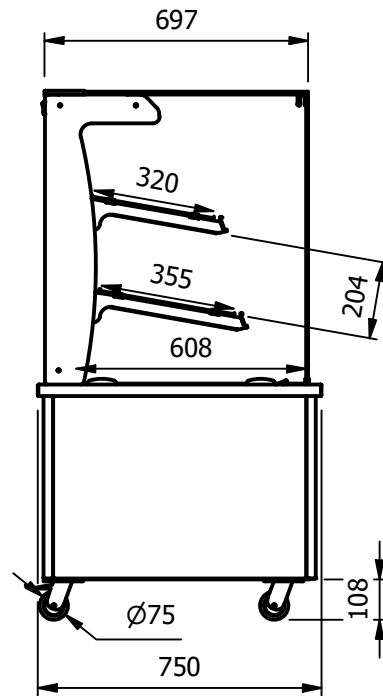

Warning
A clear space
of 600mm must
be left at the rear

AirFlow>>
<<AirFlow

Moffat Specification

Dimensions

Width - 900mm

Depth - 750mm

Height - 1400mm

Weight - 129kg

Capacity

2 shelves & bottom deck

Usable space = 2.24m³ or 224 liters

Power Rating

1.5kw

complete with a 2m long cord set & 13amp plug

Materials

0.7mm 430 Grade St/Steel inner panels

1.2mm 304 Grade St/ Steel structure

1.2mm 430 Grade St Steel Ancillary Parts

6mm thick Tempered Glass

LED Illumination

Installation

Mobile with all swivel castors two braked

ALL SHEET METAL DIMENSIONS ARE I/S (INSIDE SIZES) (UNLESS OTHERWISE STATED)

ALL DIMENSIONS IN (mm), TOLERANCE = LINEAR ± 0.5mm, ANGULAR ± 0.5mm (OR AS STATED). ALL SHARP EDGES TO BE REMOVED FROM SHEET METAL PARTS

Product	PATISSERIE RANGE			Product No							
Description	*** PAT2CSL ***										
Material/Finish	Thickness			Desp/Date							
Legacy P/N	Weight	129kg		Quote No.							
Client				SO Number	STANDARD		Dwg No.	CTRA-086985-1	Issue		
Client Project				Approved By			Drawn By	ABB	-		
E & R MOFFAT LTD, SEABEGS ROAD, BONNYBRIDGE, FK4 2BS, T: +44 (0)1324 812272, E: sales@ermoffat.co.uk, Web: www.ermoffat.co.uk							Date	10/11/2020			
							Scale	1 : 20	Sheet	1 / 2	A4

No reproduction or publication of this drawing may be made, and no article may be manufactured or assembled in accordance with this drawing without prior written consent. This prohibition is a term of any contract relating to this drawing. Rights reserved under the Copyright Act 1956 as amended by the Design Copyright Act 1968.

