

**Important Design Parameters**

Allowances must be made for air venting.  
 The under slung compressor must have an unrestricted air flow.  
 Proper venting must be provided ensuring cool air from the room can be drawn in through the condensing coil and out the other side.

**Warning**

Do not install unit in draughty conditions where the air movement is greater than 0.2mtr/sec. e.g. near entrance/exit doors, open windows, under air conditioning units or a ceiling mounted fan  
 Do not install units where there is high radiated heat, e.g. direct sunlight, room heaters, or bright spot lights.  
 Ambient room conditions must not exceed 25°C or a relative humidity of 60%.  
 Blocked vents will cause reduced refrigeration efficiency and lead to malfunction

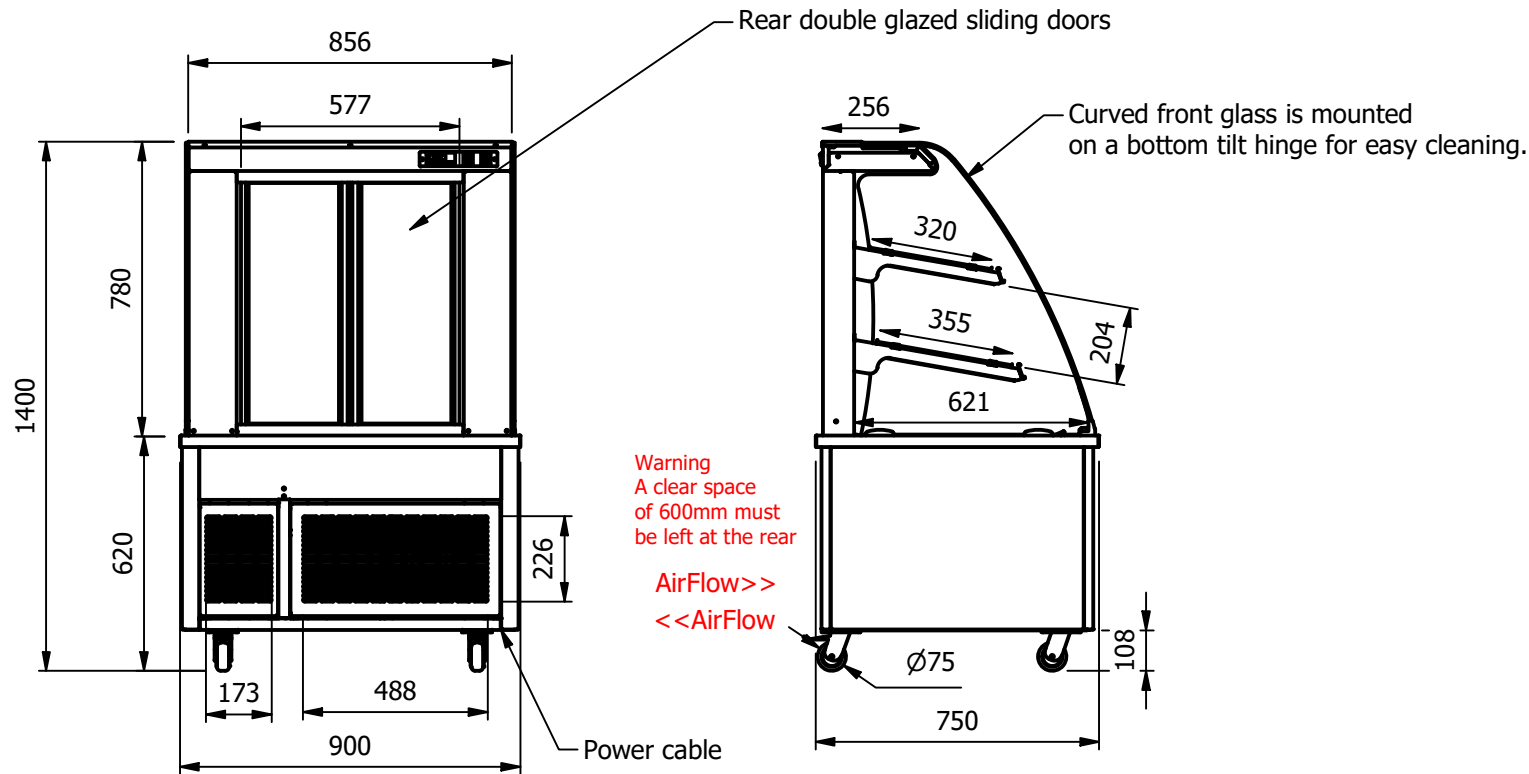
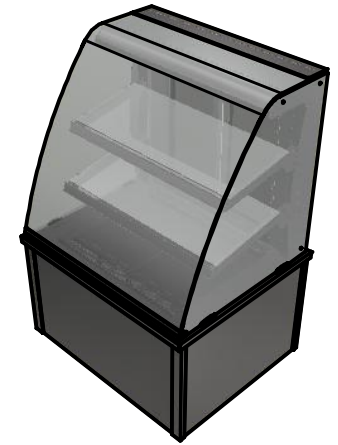

**Moffat Specification**

Dimensions

Width - 900mm  
 Depth - 750mm  
 Height - 1400mm  
 Weight - 121kg

Capacity

2 shelves & bottom deck  
 Usable space = 2.26m<sup>3</sup> or 226 liters

Power Rating

1.5kw  
 complete with a 2m long cord set & 13amp plug

Materials

0.7mm 430 Grade St/Steel inner panels  
 1.2mm 304 Grade St/ Steel structure  
 1.2mm 430 Grade St Steel Ancillary Parts  
 6mm thick Tempered Glass  
 LED Illumination

Installation

Mobile with all swivel castors two braked

ALL SHEET METAL DIMENSIONS ARE I/S (INSIDE SIZES) (UNLESS OTHERWISE STATED)

ALL DIMENSIONS IN (mm), TOLERANCE = LINEAR ± 0.5mm, ANGULAR ± 0.5mm (OR AS STATED). ALL SHARP EDGES TO BE REMOVED FROM SHEET METAL PARTS

Product	PÂTISSERIE RANGE			Product No							
Description	*** PAT2C ***										
Material/Finish	Thickness			Desp/Date							
Legacy P/N	Weight	121kg		Quote No.							
Client				SO Number	STANDARD		Dwg No.	CTRA-082477-1	Issue		
Client Project				Approved By			Drawn By	ABB	-		
							Date	10/11/2020			
E & R MOFFAT LTD, SEABEGS ROAD, BONNYBRIDGE, FK4 2BS, T: +44 (0)1324 812272, E: sales@ermoffat.co.uk, Web: www.ermoffat.co.uk							Scale	1 : 20	Sheet	1 / 3	<b>A4</b>

No reproduction or publication of this drawing may be made, and no article may be manufactured or assembled in accordance with this drawing without prior written consent. This prohibition is a term of any contract relating to this drawing. Rights reserved under the Copyright Act 1956 as amended by the Design Copyright Act 1968.

