

P2HHG
 Power loading 2.46kw
 Supply cord 1 x 13amp

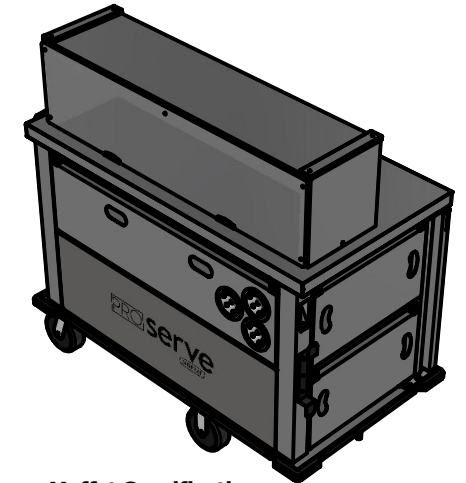

Moffat Specification

Dimensions

Width - 740mm
 Length - 1330mm
 Height - 1282mm
 Weight - 162kg

Power Rating

2.46 kw.
 complete with a 2m long cord set & 13amp plug.

Materials

1.2mm 304 & 430 Grade St/ Steel Top & Supports.
 0.7 & 1.2mm 430 Grade St Steel Ancillary Parts.
 Plastic Coated Steel Front and Side panels.
 Fully Insulated Compartment.

Mobility

Castors :- 2 Swivel Type With Brakes, 2 Fixed Direction.

Control

Rotary knob with digital display

Hotcupboard [2off]

Capacity 2 x 113 liters 0.113m3
 8off Gn1/1 Grid shelf positions @ 71mm pitch

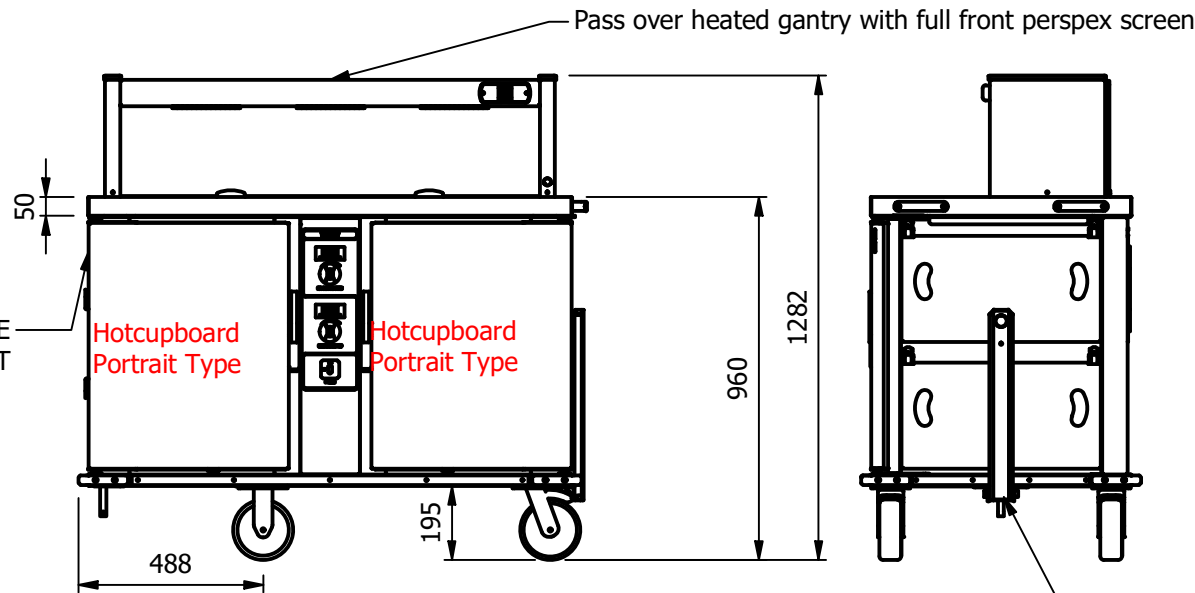

ALL SHEET METAL DIMENSIONS ARE I/S (INSIDE SIZES) (UNLESS OTHERWISE STATED)

ALL DIMENSIONS IN (mm), TOLERANCE = LINEAR ± 0.5mm, ANGULAR ± 0.5mm (OR AS STATED). ALL SHARP EDGES TO BE REMOVED FROM SHEET METAL PARTS

Product	TROLLEYS			Product No							
Description	### P2HHG ###										
Material/Finish	Thickness				Desp/Date						
Legacy P/N	Weight	162			Quote No.	MD No.	VAR-169725-1	Issue			
Client				SO Number	N/A		Drawn By	ABB			
Client Project				Approved By			Date	27/10/2025			
E & R MOFFAT LTD, SEABEGS ROAD, BONNYBRIDGE, FK4 2BS, T: +44 (0)1324 812272, E: sales@ermoffat.co.uk, Web: www.ermoffat.co.uk							Scale	1 : 20	Sheet	1 / 1	A4

No reproduction or publication of this drawing may be made, and no article may be manufactured or assembled in accordance with this drawing without prior written consent. This prohibition is a term of any contract relating to this drawing. Rights reserved under the Copyright Act 1956 as amended by the Design Copyright Act 1968.

