

P2HHB
 Power loading 2.04kw
 Supply cord 1 x 13amp

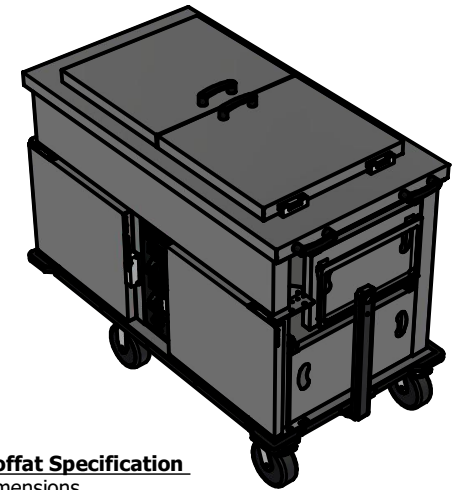

Moffat Specification

Dimensions
 Width - 740mm
 Depth - 1330mm
 Height - 1046mm
 Weight - 175kg

Power Rating
 2.04 kw.
 complete with a 2m long cord set & 13amp plug.

Materials
 1.2mm 304 & 430 Grade St/ Steel Top & Supports.
 0.7 & 1.2mm 430 Grade St Steel Ancillary Parts.
 Plastic Coated Steel Front and Side panels.
 Fully Insulated Compartment.

Mobility
 Castors :- 2 Swivel Type With Brakes, 2 Fixed Direction.

Control
 Rotary knob with digital display

Hotcupboard [2off]
 Capacity 2 x 75 litres 0.075m3
 5off Gn1/1 Grid shelf positions @ 71mm pitch

Bainmarie
 3off GN 1/1 size 150mm deep

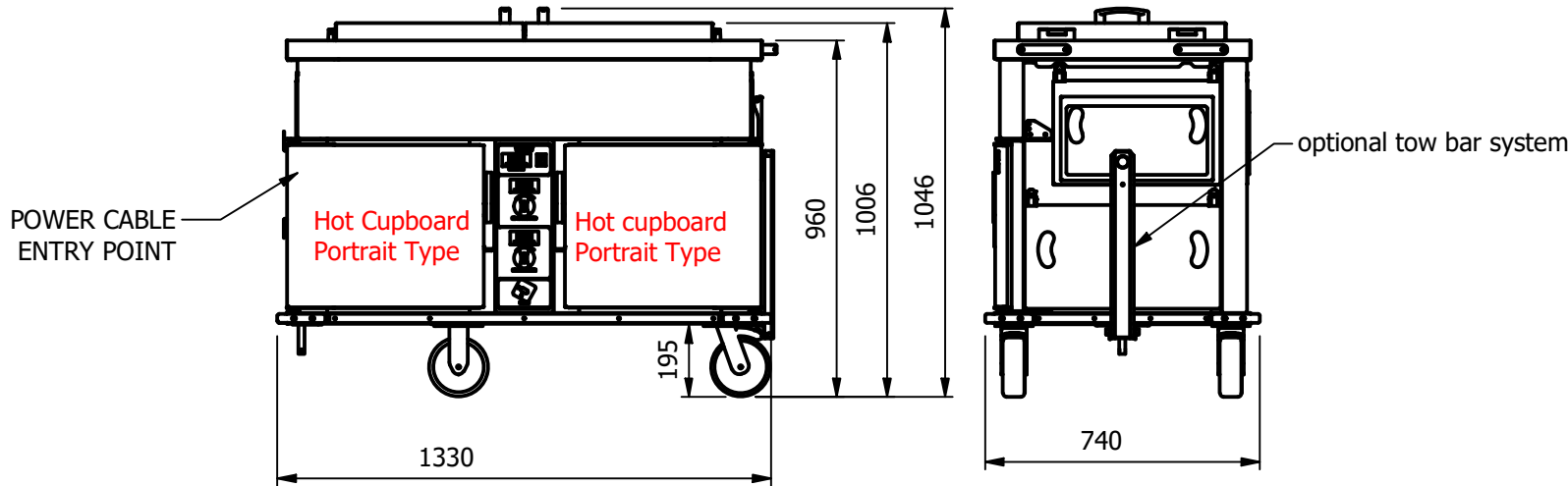

ALL SHEET METAL DIMENSIONS ARE I/S (INSIDE SIZES) (UNLESS OTHERWISE STATED)

ALL DIMENSIONS IN (mm), TOLERANCE = LINEAR ± 0.5mm, ANGULAR ± 0.5mm (OR AS STATED). ALL SHARP EDGES TO BE REMOVED FROM SHEET METAL PARTS

Product	TROLLEYS			Product No				
Description	### P2HHB ###			<small>© No reproduction or publication of this drawing may be made, and no article may be manufactured or assembled in accordance with this drawing without prior written consent. This prohibition is a term of any contract relating to this drawing. Rights reserved under the Copyright Act 1956 as amended by the Design Copyright Act 1968.</small>				
Material/Finish	Thickness			Desp/Date	 The Catering Equipment Company			
Legacy P/N	Weight	175kg		Quote No.	Dwg No.	VAR-102602	Issue	
Client				SO Number	N/A		Drawn By	ABB
Client Project				Approved By			Date	18/11/2025
E & R MOFFAT LTD, SEABEGS ROAD, BONNYBRIDGE, FK4 2BS, T: +44 (0)1324 812272, E: sales@ermoffat.co.uk, Web: www.ermoffat.co.uk					Scale	1 : 25	Sheet	1 / 4
								A4