

Models:
 P2GRE13 - 2.7 kw 2 x 13amp 1 phase
 P2GRE16 - 2.7 kw 16amp 1 phase
 P2GRE163 - 2.7 kw 16amp 3 phase
 P2GRE323 - 2.7 kw 32amp 3 phase

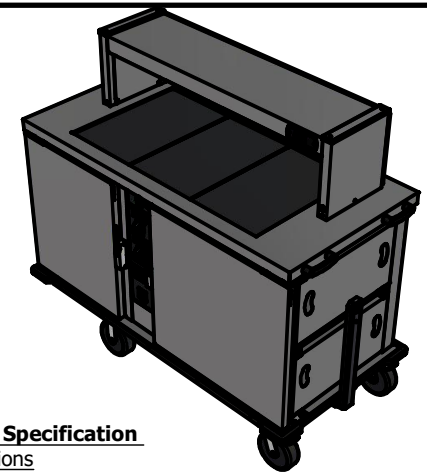

Moffat Specification

Dimensions

Width - 740mm
 length - 1478mm
 Height - 1282mm
 Weight - 180kg

Power Rating

2.7 kw.
 complete with a 2m long cord set & 2 x 13amp plug.

Materials

1.2mm 304 & 430 Grade St/ Steel Top & Supports.
 0.7 & 1.2mm 430 Grade St Steel Ancillary Parts.
 Plastic Coated Steel Front and Side panels.
 Fully Insulated Compartment.

Mobility

Castors :- 2 Swivel Type With Brakes, 2 Fixed Direction.

Control

Rotary knob with digital display

Oven

Capacity 113litres
 8off Gn1/1 Grid shelf positions @ 71mm pitch

Fridge

Capacity 113litres
 8off Gn1/1 Grid shelf positions @ 71mm pitch

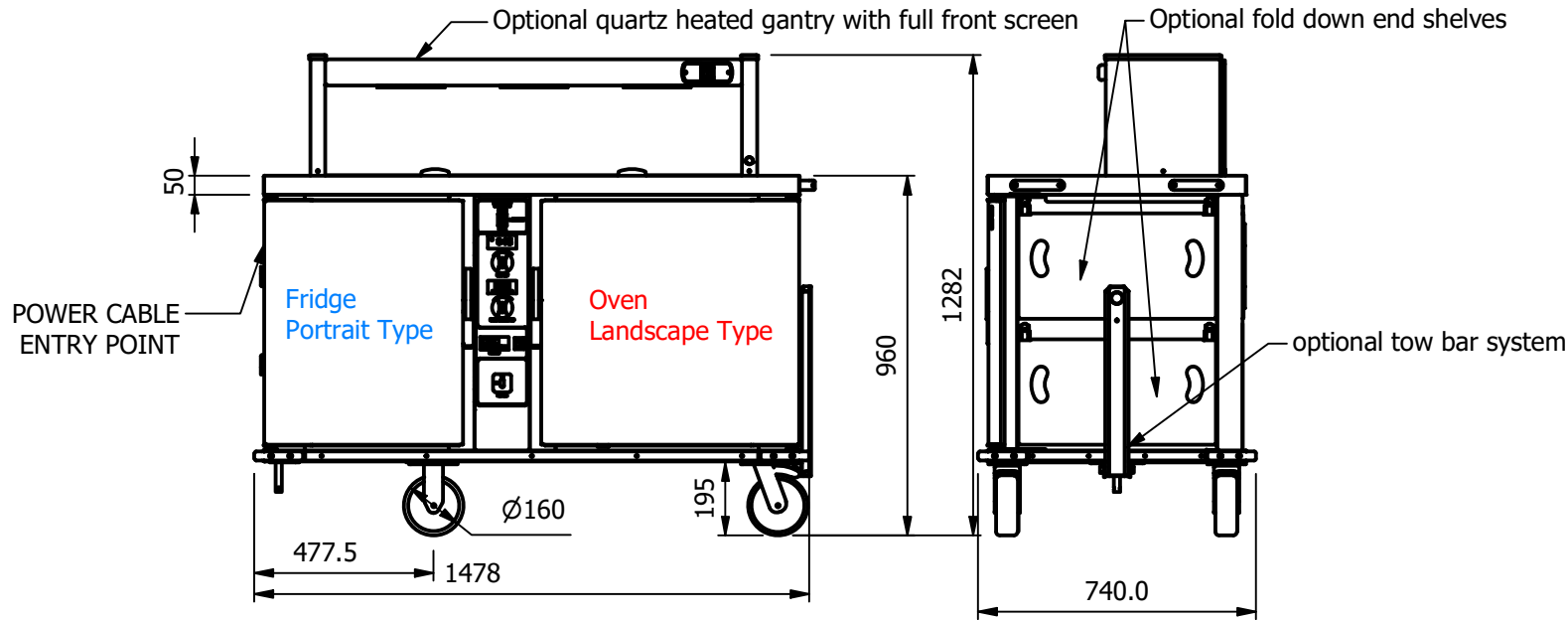

ALL SHEET METAL DIMENSIONS ARE I/S (INSIDE SIZES) (UNLESS OTHERWISE STATED)

ALL DIMENSIONS IN (mm), TOLERANCE = LINEAR ± 0.5mm, ANGULAR ± 0.5mm (OR AS STATED). ALL SHARP EDGES TO BE REMOVED FROM SHEET METAL PARTS

Product	TROLLEYS			Product No		<p>The Catering Equipment Company</p>	<small>No reproduction or publication of this drawing may be made, and no article may be manufactured or assembled in accordance with this drawing without prior written consent. This prohibition is a term of any contract relating to this drawing. Rights reserved under the Copyright Act 1956 as amended by the Design Copyright Act 1968.</small>			
Description	### P2GRE ###									
Material/Finish	Thickness			Desp/Date						
Legacy P/N	Weight	180kg		Quote No.		Dwg No.	VAR-162080	Issue		
Client				SO Number	N/A	Drawn By	ABB	-		
Client Project				Approved By		Date	14/11/2025			
E & R MOFFAT LTD, SEABEGS ROAD, BONNYBRIDGE, FK4 2BS, T: +44 (0)1324 812272, E: sales@ermoffat.co.uk, Web: www.ermoffat.co.uk						Scale	1 : 20	Sheet	1 / 5	A4