

**Overview**

Models P2GGE – Dual Ovens with a Neo-Ceram Hot Top & Gantry.

Models P2GGENG – Dual Ovens with a Neo-Ceram Hot Top.

**Cook & Serve**

Designed specifically for the education sector where simplicity and easy to use is key.

Cooking /regeneration and serving of fresh, chilled or frozen bulk food.

These units allow cook & serve at the point of consumption. Useful for multi-food portioning and multi-food choice. Complete with a self-regulating black glass hot-top. The double oven capacity with unique multi-fan air re-circulation system allows fast and even heat distribution throughout. Optimized for GN (Gastronorm) containers, there are eight shelf position in each oven set at 71 mm intervals . This allows up to eight GN 1/1 containers per oven. This unit ensures hot food is cooked and stays at the ideal serving temperature during service. The ovens have a bright, polished, stainless steel interior, satin finished outer panels, and plastic coated front and sides. Complete with heavy duty hinged doors and slam shut door catches.



P2GGE (with gantry)

P2GGE models have a gantry pass over shelf with full front screen, this is illuminated and heated by quartz type lamps.

**Features:**

- 1/1 GN compatible. Simple to transfer to serving area or load from a companion trolley.
- Neo-Ceram, thermo-panel hot top (self regulates around 95°C)
- Steam automatic evac & oven door air curtains.
- Digital timer and thermostats guarantee precise time and temperature control.
- Simply rotary controls, temperature and count down timer display, with an audible buzzer.
- Multi fans deliver even heating across the entire oven chamber, ensuring consistent cooking results.
- Designed for bulk production, with 8 shelf capacity in each oven (shelf pitch is 71mm)
- Wide choice of coloured front & end panels (standard colour is Goose Wing Grey)
- 4 x precision castors, 2 swivel with brakes and 2 fixed (easy to push in a straight line)
- Wheels are off set allowing a tight turning circle.
- Shelving and supports are removable for easy cleaning
- Hi-Tech insulation
- Cool to touch door with fully adjustable heavy duty hinges and a slam catch maintaining a tight seal.



P2GGENG (no gantry)

**Accessories:**

- Fold-down end shelves, up to four can be fitted, two on each side.
- Fold down waste bag holder. This can be fitted on the left or right hand side.
- Fold-down front tray-slide with 3 apertures for cutlery holders.
- Cutlery holders cups for front tray slide option.
- Additional grid shelves. Note: a full compliment of 16 shelves are supplied.
- Tow bar & hitch attachment.
- Gastronorm containers.



P2GGE

Shown with optional fold down end shelves and front tray slide



“Deliver efficiency with every meal – Pro Serve meal service trolleys are designed to keep food hot, service smooth, and operations effortless.”

## P2GGE



Models	Weight (kg)	Length x Width x Height (mm)	Electrical Supply	Power Rating on cook mode (kw)	Power Rating serve mode (kw)
P2GGE13	182	1330 x 740 x 1282	2 x 13amp 1 PH	5.4	3.0
P2GGE32	182	1330 x 740 x 1282	1 x 32amp 1PH	5.4	3.0
P2GGE163	182	1330 x 740 x 1282	1 x 16amp 3PH	5.4	3.0
P2GGE323	182	1330 x 740 x 1282	1 x 32amp 3PH	5.4	3.0
P2GGENG13	171	1330 x 740 x 960	2 x 13amp 1 PH	5.4	2.34
P2GGENG32	171	1330 x 740 x 960	1 x 32amp 1PH	5.4	2.34
P2GGENG163	171	1330 x 740 x 960	1 x 16amp 3PH	5.4	2.34
P2GGENG323	171	1330 x 740 x 960	1 x 32amp 3PH	5.4	2.34

### These models have clever and simple operation modes Cook / Standby / Serve

**Cook mode:** Full power to the ovens, the power to the Hot top and optional Gantry is automatically inhibited.

**Standby mode:** Power to ovens and hot top is switched off.

**Serve mode:** Power to the ovens is limited to keep hot only, Power to Hot top and optional Gantry is switched on.

	Left-Hand Oven Capacity (Usable space totals 113 litres)	Right-Hand Oven Capacity (Usable space totals 113 litres)	Glass Top Area (Heated area)
Width	325 mm	325 mm	980 mm
Depth	530 mm	530 mm	530 mm
Pitch (per shelf)	71 mm	71 mm	N/A
	8 Grid Shelf Positions (8 Supplied)	8 Grid Shelf Positions (8 Supplied)	

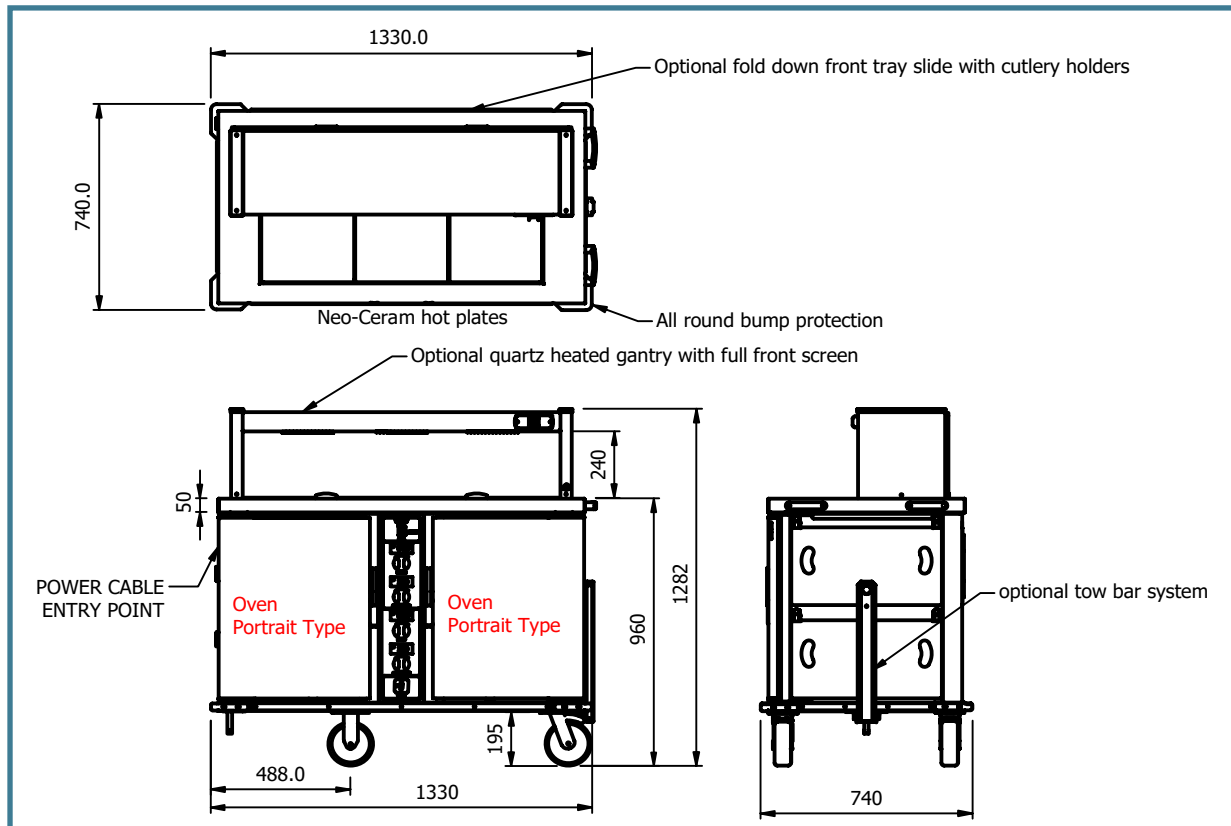

MADE IN BRITAIN

E&R Moffat Ltd.  
Bonnybridge  
FK4 2BS  
Scotland



www.ermoffat.co.uk  
+44 (0) 1324 812272  
sales@ermoffat.co.uk