

Moffat Specification

Dimensions

Width - 740mm
 Depth - 1330mm
 Height - 1372mm
 Weight - 175kg

Power Rating Options

P2GG13 - 5.0 kw 2 x 13amp 1PH
 P2GG163 - 5.0 kw 1 x 16amp 3Ph
 complete with a 2m long cord set & plugs.

Materials

1.2mm 304 & 430 Grade St/ Steel Top & Supports.
 0.7 & 1.2mm 430 Grade St Steel Ancillary Parts.
 Plastic Coated Steel Front and Side panels.
 6mm Perspex Full Front Screen.
 Neo-Ceram Hot Top Area 1210mm x 590mm.
 LED Illumination.
 Fully Insulated Compartment.

Mobility

Castors :- 2 Swivel Type With Brakes, 2 Fixed Direction.

Control

Fully Programmably For 24/7 Operation.

Oven [2off]

Capacity 113Litres
 8off Gn1/1 Grid shelf positions @ 71mm pitch

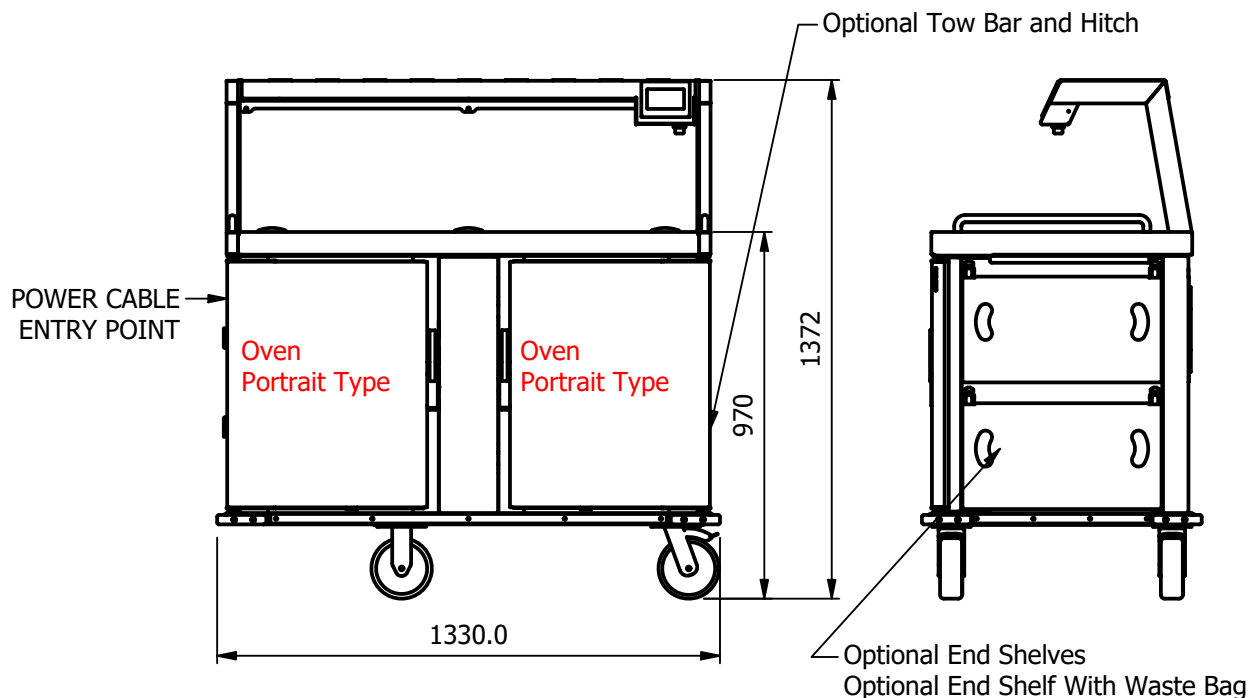

ALL SHEET METAL DIMENSIONS ARE I/S (INSIDE SIZES) (UNLESS OTHERWISE STATED)

ALL DIMENSIONS IN (mm), TOLERANCE = LINEAR ± 0.5mm, ANGULAR ± 0.5mm (OR AS STATED). ALL SHARP EDGES TO BE REMOVED FROM SHEET METAL PARTS

Product	TROLLEYS			Product No				
Description	###P2GG###			<small>© No reproduction or publication of this drawing may be made, and no article may be manufactured or assembled in accordance with this drawing without prior written consent. This prohibition is a term of any contract relating to this drawing. Rights reserved under the Copyright Act 1956 as amended by the Design Copyright Act 1968.</small>				
Material/Finish	Thickness			Desp/Date				
Legacy P/N	Weight	175kg		Quote No.	MD No.	VAR-162154-1	Issue	
Client				SO Number	N/A		Drawn By	ABB
Client Project				Approved By			Date	26/11/2025
E & R MOFFAT LTD, SEABEGS ROAD, BONNYBRIDGE, FK4 2BS, T: +44 (0)1324 812272, E: sales@ermoffat.co.uk, Web: www.ermoffat.co.uk					Scale	1 : 20	Sheet	1 / 4
								A4

