

Models:
 P2GGE13 - 5.4 kw 2 x 13amp 1 phase
 P2GGE32 - 5.4 kw 1 x 32amp 1 phase
 P2GGE163 - 5.4 kw 1 x 16amp 3 phase
 P2GGE323 - 5.4 kw 1 x 32amp 3 phase

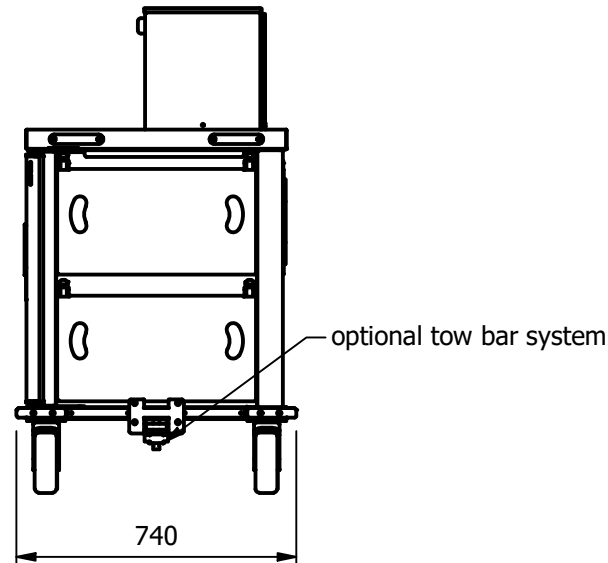
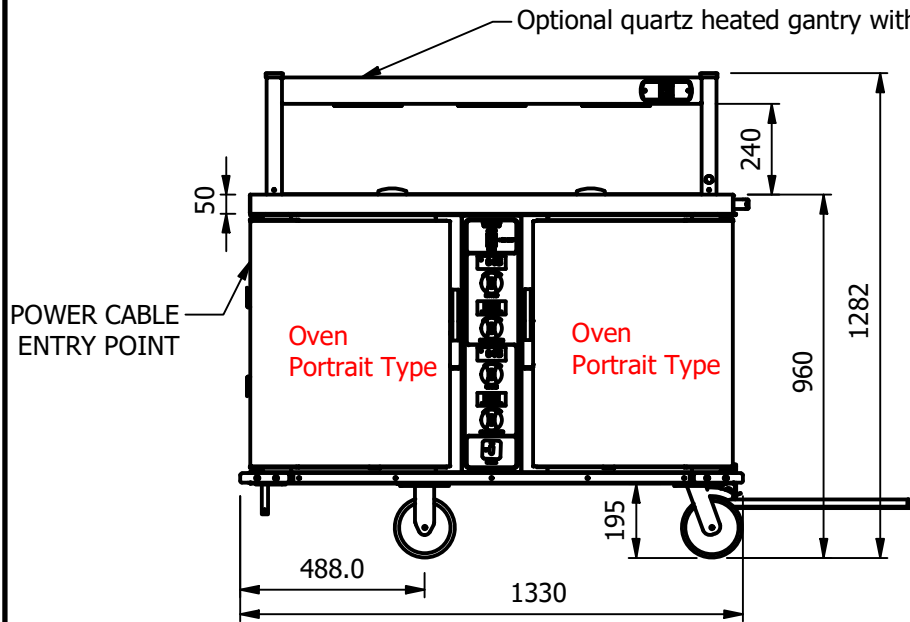
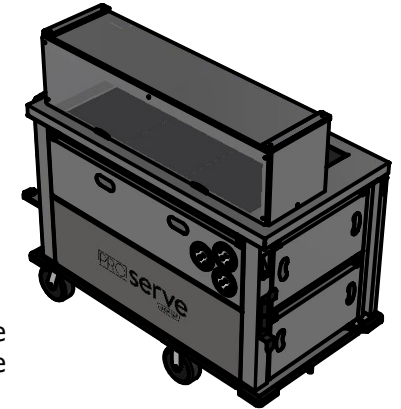

Moffat Specification

Dimensions
 Width - 740mm
 length - 1330mm
 Height - 1282mm
 Weight - 182kg

Power Rating
 5.4kw.
 complete with a 2m long cord set & 13amp plug.

Materials
 1.2mm 304 & 430 Grade St/ Steel Top & Supports.
 0.7 & 1.2mm 430 Grade St Steel Ancillary Parts.
 Plastic Coated Steel Front and Side panels.
 Fully Insulated Compartment.

Mobility
 Castors :- 2 Swivel Type With Brakes, 2 Fixed Direction.

Control
 Rotary knob with digital display

Ovens [2off]
 Capacity 113 liters 0.113m3
 8off Gn1/1 Grid shelf positions @ 71mm pitch

ALL SHEET METAL DIMENSIONS ARE I/S (INSIDE SIZES) (UNLESS OTHERWISE STATED)

ALL DIMENSIONS IN (mm), TOLERANCE = LINEAR ± 0.5mm, ANGULAR ± 0.5mm (OR AS STATED). ALL SHARP EDGES TO BE REMOVED FROM SHEET METAL PARTS

Product	TROLLEYS			Product No		 The Catering Equipment Company				
Description	### P2GGE ###									
Material/Finish	Thickness			Desp/Date						
Legacy P/N	Weight	182		Quote No.		Dwg No.	VAR-161502	Issue		
Client				SO Number	N/A	Drawn By	ABB			
Client Project				Approved By		Date	14/11/2025			
E & R MOFFAT LTD, SEABEGS ROAD, BONNYBRIDGE, FK4 2BS, T: +44 (0)1324 812272, E: sales@ermoffat.co.uk, Web: www.ermoffat.co.uk						Scale	1 : 30	Sheet	1 / 5	A4

No reproduction or publication of this drawing may be made, and no article may be manufactured or assembled in accordance with this drawing without prior written consent. This prohibition is a term of any contract relating to this drawing. Rights reserved under the Copyright Act 1956 as amended by the Design Copyright Act 1968.