

CENTER RUNNER SECTION
ADJUSTABLE TO SUIT
GASTRONORM TRAYS
OR EURONORM TRAYS

(GASTRONORM TRAY = 530mm x 325mm)
(EURONORM TRAY = 530mm x 370mm)

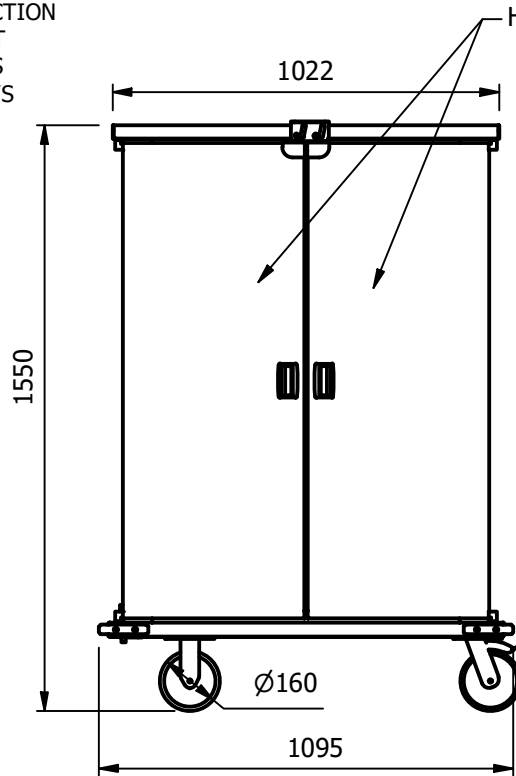

Hinged doors on one side only

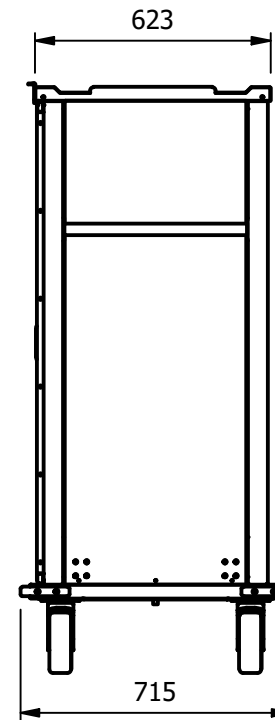

Moffat Specification

- Fully Insulated Compartment.
- 20 off shelf positions @ 120mm pitch
- Adjustable to suit Gastronorm or Euronorm type trays.

Gastronorm tray = 530mm x 325mm
[maximum tray space 560mm x 335mm]

Euronorm tray = 530mm x 370mm
[maximum tray space 560mm x 380mm]

Dimensions
Width - 1095mm
Depth - 715mm
Height - 1550mm
Weight - 130kg

Materials
1.2mm 430 Grade St/ Steel Chassis Top & Supports.
0.7 & 1.2mm 430 Grade St Steel Ancillary Parts.
Plastic Coated Steel Front Side and door panels.

Mobility
Castors :- 2 Swivel Type With Brakes, 2 Fixed Direction.

ALL SHEET METAL DIMENSIONS ARE I/S (INSIDE SIZES) (UNLESS OTHERWISE STATED)

ALL DIMENSIONS IN (mm), TOLERANCE = LINEAR ± 0.5mm, ANGULAR ± 0.5mm (OR AS STATED). ALL SHARP EDGES TO BE REMOVED FROM SHEET METAL PARTS

Product	TROLLEYS			Product No							
Description	MTT20										
Material/Finish	Thickness			Desp/Date							
Legacy P/N	Weight	130kg		Quote No.							
Client				SO Number	*STANDARD*		Dwg No.	VCP-075813	Issue		
Client Project				Approved By			Drawn By	nraymen	-		
E & R MOFFAT LTD, SEABEGS ROAD, BONNYBRIDGE, FK4 2BS, T: +44 (0)1324 812272, E: sales@ermoffat.co.uk, Web: www.ermoffat.co.uk							Date	07/09/2019			
							Scale	1 : 20	Sheet	1 / 2	A4

No reproduction or publication of this drawing may be made, and no article may be manufactured or assembled in accordance with this drawing without prior written consent. This prohibition is a term of any contract relating to this drawing. Rights reserved under the Copyright Act 1956 as amended by the Design Copyright Act 1968.

