

CENTER RUNNER SECTION  
ADJUSTABLE TO SUIT  
GASTRONORM TRAYS  
OR EURONORM TRAYS

(GASTRONORM TRAY = 530mm x 325mm)  
(EURONORM TRAY = 530mm x 370mm)

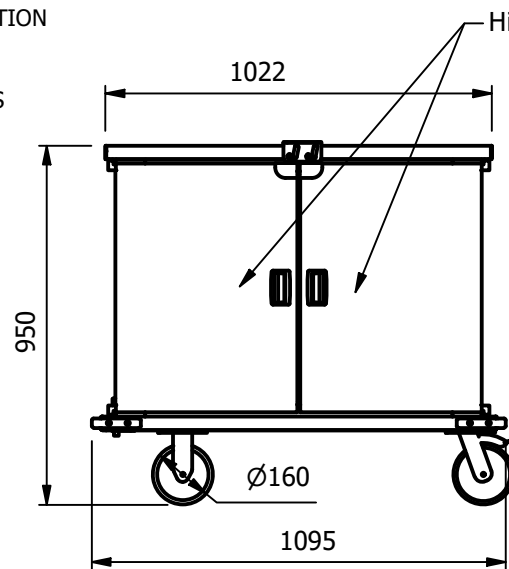

Hinged doors on one side only

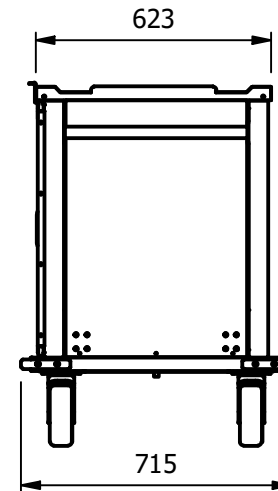

**Moffat Specification**

Fully Insulated Compartment.  
10off shelf positions @ 120mm pitch

Adjustable to suit Gastronorm or Euronorm type trays.

Gastronorm tray = 530mm x 325mm  
[maximum tray space 560mm x 335mm]

Euronorm tray = 530mm x 370mm  
[maximum tray space 560mm x 380mm]

Dimensions

Width - 1095mm  
Depth - 715mm  
Height - 950mm  
Weight - 110kg

Materials

1.2mm 430 Grade St/ Steel Chassis Top & Supports.  
0.7 & 1.2mm 430 Grade St Steel Ancillary Parts.  
Plastic Coated Steel Front Side and door panels.

Mobility

Castors :- 2 Swivel Type With Brakes, 2 Fixed Direction.

ALL SHEET METAL DIMENSIONS ARE I/S (INSIDE SIZES) (UNLESS OTHERWISE STATED)

ALL DIMENSIONS IN (mm), TOLERANCE = LINEAR ± 0.5mm, ANGULAR ± 0.5mm (OR AS STATED). ALL SHARP EDGES TO BE REMOVED FROM SHEET METAL PARTS

Product	TROLLEYS			Product No			
Description	MTT10						
Material/Finish	Thickness		Desp/Date				
Legacy P/N	Weight	110kg	Quote No.				
Client				SO Number	*STANDARD*		
Client Project				Approved By			
				Dwg No.	VCP-075817	Issue	
				Drawn By	nraymen		
				Date	07/09/2019		
E & R MOFFAT LTD, SEABEGS ROAD, BONNYBRIDGE, FK4 2BS, T: +44 (0)1324 812272, E: sales@ermoffat.co.uk, Web: www.ermoffat.co.uk				Scale	1 : 20	Sheet	1 / 2   <b>A4</b>

No reproduction or publication of this drawing may be made, and no article may be manufactured or assembled in accordance with this drawing without prior written consent. This prohibition is a term of any contract relating to this drawing. Rights reserved under the Copyright Act 1956 as amended by the Design Copyright Act 1968.

