

**Moffat Specification**

Dry Heat  
Fan Assisted Hotcupboard

Dimensions  
Length - 1124mm  
Depth - 560mm ( 610mm with folded tray slide)  
Height - 868mm  
Weight - 55kg

Capacity of Hot Cupboard [usable inside space]  
Length - 981mm  
Depth - 538mm

Fitted with three removable shelves  
usable height between shelves 154mm

24 covers & meals [10" plated meals stacked using plate covers]  
or  
72 off 10" plates stacked for heating  
or  
16 Standard Grundy tins (409mm x 267mm x 57mm)  
or  
9 off 150mm deep 1/2GN pans side by side.

Power Rating  
1.5kw  
complete with a 2m long cord set & 13amp plug  
Removable Fan heating System Sahara Fan Model SF315

Materials  
1.2mm 304 Grade St/ Steel Top & Supports  
0.7mm 430 Grade St/ Steel Internal Structure

Installation  
All swivel castors, two braked

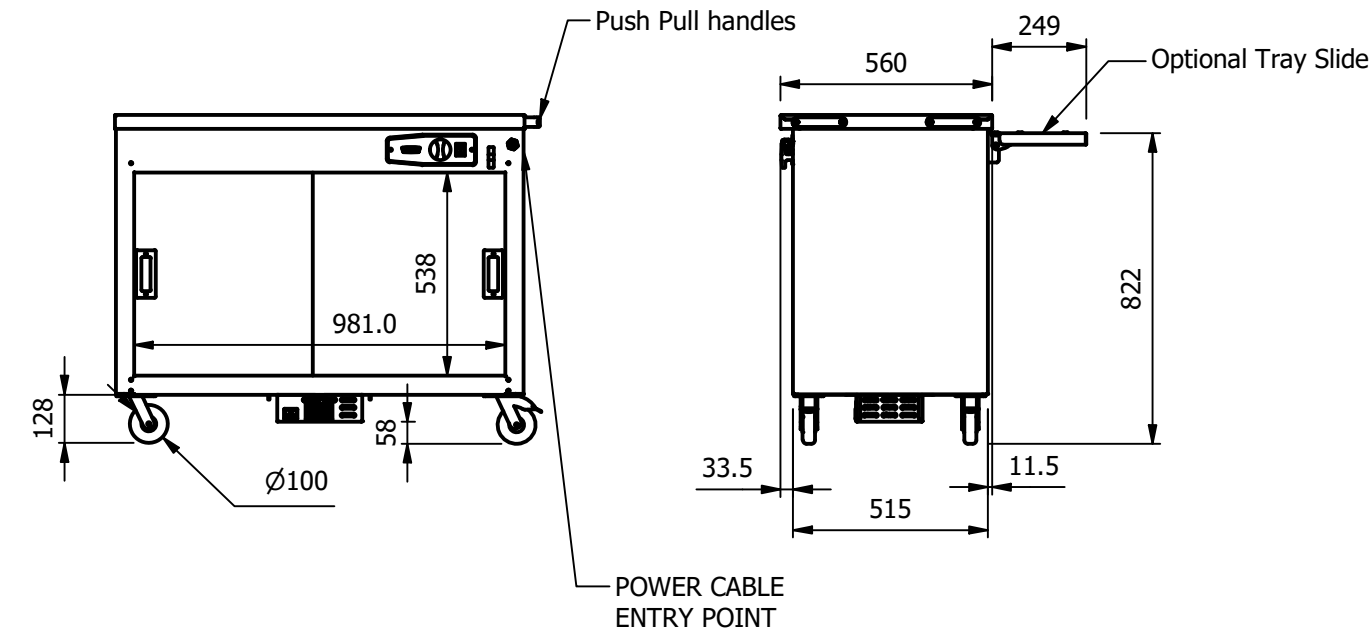

ALL SHEET METAL DIMENSIONS ARE I/S (INSIDE SIZES) (UNLESS OTHERWISE STATED)

ALL DIMENSIONS IN (mm), TOLERANCE = LINEAR ± 0.5mm, ANGULAR ± 0.5mm (OR AS STATED). ALL SHARP EDGES TO BE REMOVED FROM SHEET METAL PARTS

Product	MH9			Product No							
Description	*** MHB9 ***										
Material/Finish	Thickness			Desp/Date							
Legacy P/N	Weight	55kg		Quote No.							
Client				SO Number	STANDARD		Drawn By	N.Raymen			
Client Project				Approved By			Date	19/01/2021			
E & R MOFFAT LTD, SEABEGS ROAD, BONNYBRIDGE, FK4 2BS, T: +44 (0)1324 812272, E: sales@ermoffat.co.uk, Web: www.ermoffat.co.uk							Scale	1 : 20	Sheet	1 / 2	A4

No reproduction or publication of this drawing may be made, and no article may be manufactured or assembled in accordance with this drawing without prior written consent. This prohibition is a term of any contract relating to this drawing. Rights reserved under the Copyright Act 1956 as amended by the Design Copyright Act 1968.

