

Drawer inside dimensions
 Top drawer 505mm x 300mm x 100mm
 Middle drawer 505mm x 300mm x 100mm
 Bottom drawer 505mm x 300mm x 200mm

View with a standard work top
 with rear up-stand and 70mm rear void

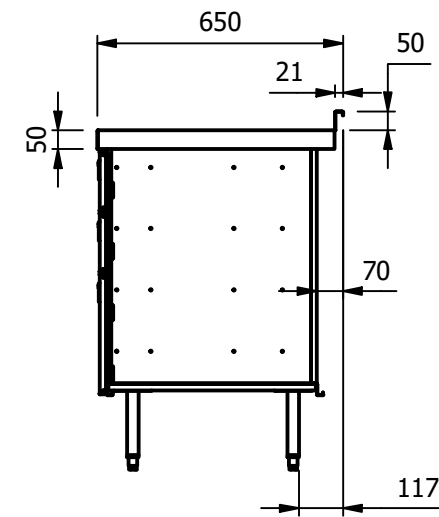
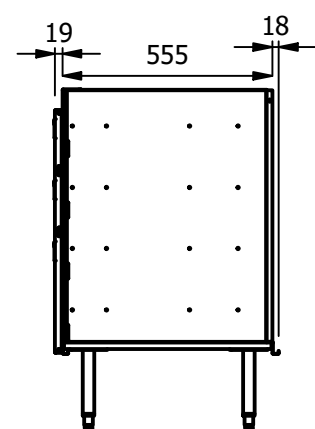
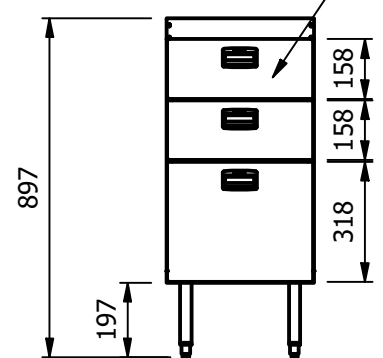

Adjustable for height legs

Moffat Specification

Floor standing drawer unit

Dimensions

Width - 390mm / 400mm with top
 Depth - 592mm / 650mm with top
 Height - 897mm / 900mm with top
 Weight - 30kg

Capacity

Top drawer GN1/1 x 100mm deep
 Middle drawer GN 1/1 x 100mm deep
 Bottom drawer GN1/1 x 200mm deep

Materials

0.7mm 430 Grade St/ Steel Structure
 1.2mm 430 Grade St/ Steel Structure

Installation

Floor Standing with adjustable height legs

ALL SHEET METAL DIMENSIONS ARE I/S (INSIDE SIZES) (UNLESS OTHERWISE STATED)

ALL DIMENSIONS IN (mm), TOLERANCE = LINEAR ± 0.5mm, ANGULAR ± 0.5mm (OR AS STATED). ALL SHARP EDGES TO BE REMOVED FROM SHEET METAL PARTS

| | | | | | |
|---|-------------|------|-------------|------------|--|
| Product | FABRICATION | | | Product No |  The Catering Equipment Company |
| Description | M1D3 | | | | |
| Material/Finish | Thickness | | Desp/Date | | <small>No reproduction or publication of this drawing may be made, and no article may be manufactured or assembled in accordance with this drawing without prior written consent. This prohibition is a term of any contract relating to this drawing. Rights reserved under the Copyright Act 1956 as amended by the Design Copyright Act 1968.</small> |
| Legacy P/N | Weight | 30kg | Quote No. | Dwg No. | |
| Client | | | SO Number | STD | UMA-072550 |
| Client Project | | | Approved By | | Issue |
| E & R MOFFAT LTD, SEABEGS ROAD, BONNYBRIDGE, FK4 2BS, T: +44 (0)1324 812272, E: sales@ermoffat.co.uk, Web: www.ermoffat.co.uk | | | | | 1 / 2 |
| | | | | | A4 |

No reproduction or publication of this drawing may be made, and no article may be manufactured or assembled in accordance with this drawing without prior written consent. This prohibition is a term of any contract relating to this drawing. Rights reserved under the Copyright Act 1956 as amended by the Design Copyright Act 1968.



| | | |
|----------|------------|-------|
| Dwg No. | UMA-072550 | Issue |
| Drawn By | ABB | - |
| Date | 05/05/2020 | |
| Scale | 1 : 20 | Sheet |