

WORK TOP FIXING POINTS

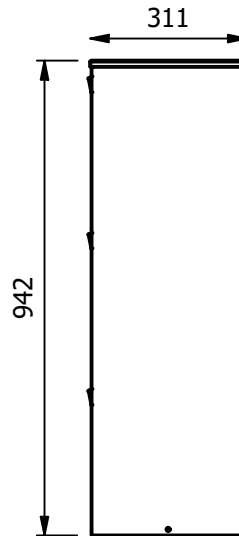
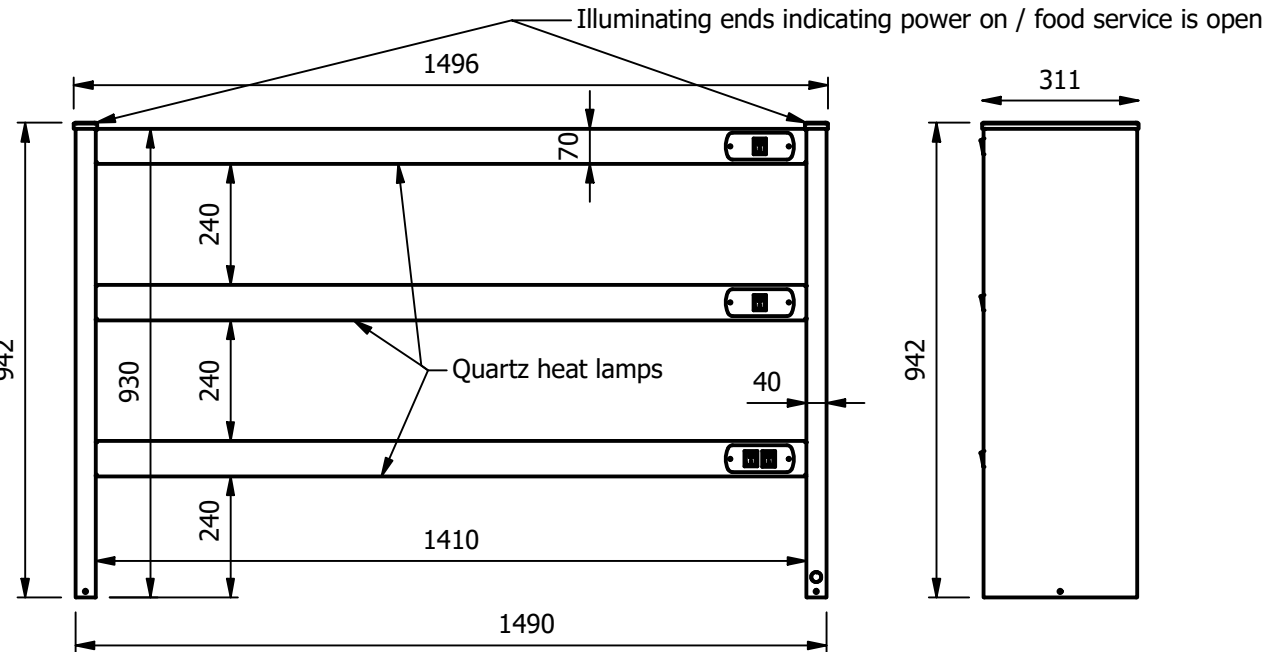
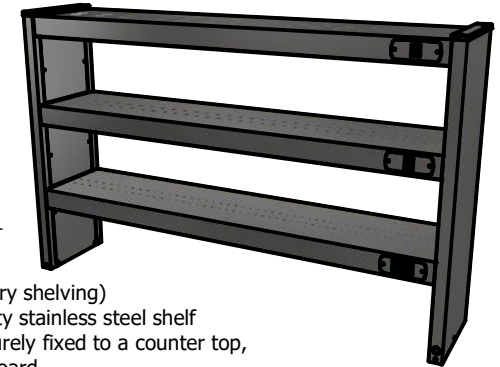

**Moffat Specification**

**Kitchen Pass**  
 (Heated overhead gantry shelving)  
 300mm wide heavy duty stainless steel shelf  
 Ready made to be securely fixed to a counter top,  
 wall bench or hot cupboard.  
 Supplied with 13amp plug and cable as standard,  
 or can be supplied hard wired into a supporting Moffat unit.

**Dimensions**  
 Length - 1496mm  
 Depth - 311mm  
 Height - 942mm  
 Weight - 42kg

**Power Rating**  
 2.64kw  
 12 x 220w lamps

**Materials**  
 1.2mm 304 Grade St/ Steel Top & Supports  
 0.7mm 430 Grade St/ Steel Internal Structure

**Installation**  
 Worktop bolt on design.

ALL SHEET METAL DIMENSIONS ARE I/S (INSIDE SIZES) (UNLESS OTHERWISE STATED)

ALL DIMENSIONS IN (mm), TOLERANCE = LINEAR ± 0.5mm, ANGULAR ± 0.5mm (OR AS STATED). ALL SHARP EDGES TO BE REMOVED FROM SHEET METAL PARTS

Product	KITCHEN PASS			Product No	 The Catering Equipment Company	
Description	*** KP4H3 ***					
Material/Finish	Thickness		Desp/Date		<small>No reproduction or publication of this drawing may be made, and no article may be manufactured or assembled in accordance with this drawing without prior written consent. This prohibition is a term of any contract relating to this drawing. Rights reserved under the Copyright Act 1956 as amended by the Design Copyright Act 1968.</small>	
Legacy P/N	Weight	42kg	Quote No.	Dwg No.		CTRA-086379
Client			SO Number	STANDARD	Issue	
Client Project			Approved By		Drawn By	ABB
				Date	31/03/2020	
E & R MOFFAT LTD, SEABEGS ROAD, BONNYBRIDGE, FK4 2BS, T: +44 (0)1324 812272, E: sales@ermoffat.co.uk, Web: www.ermoffat.co.uk				Scale	1 : 15	
				Sheet	1 / 2	
					<b>A4</b>	