

WORK TOP FIXING POINTS

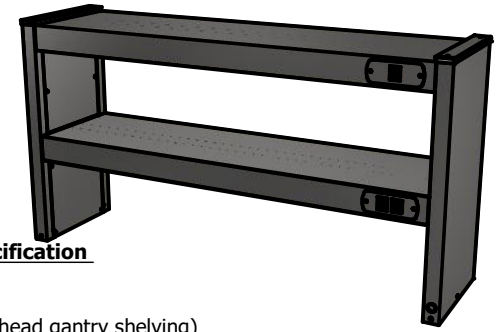

Moffat Specification

Kitchen Pass
 (Heated overhead gantry shelving)
 300mm wide heavy duty stainless steel shelf
 Ready made to be securely fixed to a counter top,
 wall bench or hot cupboard.
 Supplied with 13amp plug and cable as standard,
 or can be supplied hard wired into a supporting Moffat unit.

Dimensions
 Length - 1196mm
 Depth - 311mm
 Height - 632mm
 Weight - 22kg

Power Rating
 1.32kw
 6 x 220w lamps

Materials
 1.2mm 304 Grade St/ Steel Top & Supports
 0.7mm 430 Grade St/ Steel Internal Structure

Installation
 Worktop bolt on design.

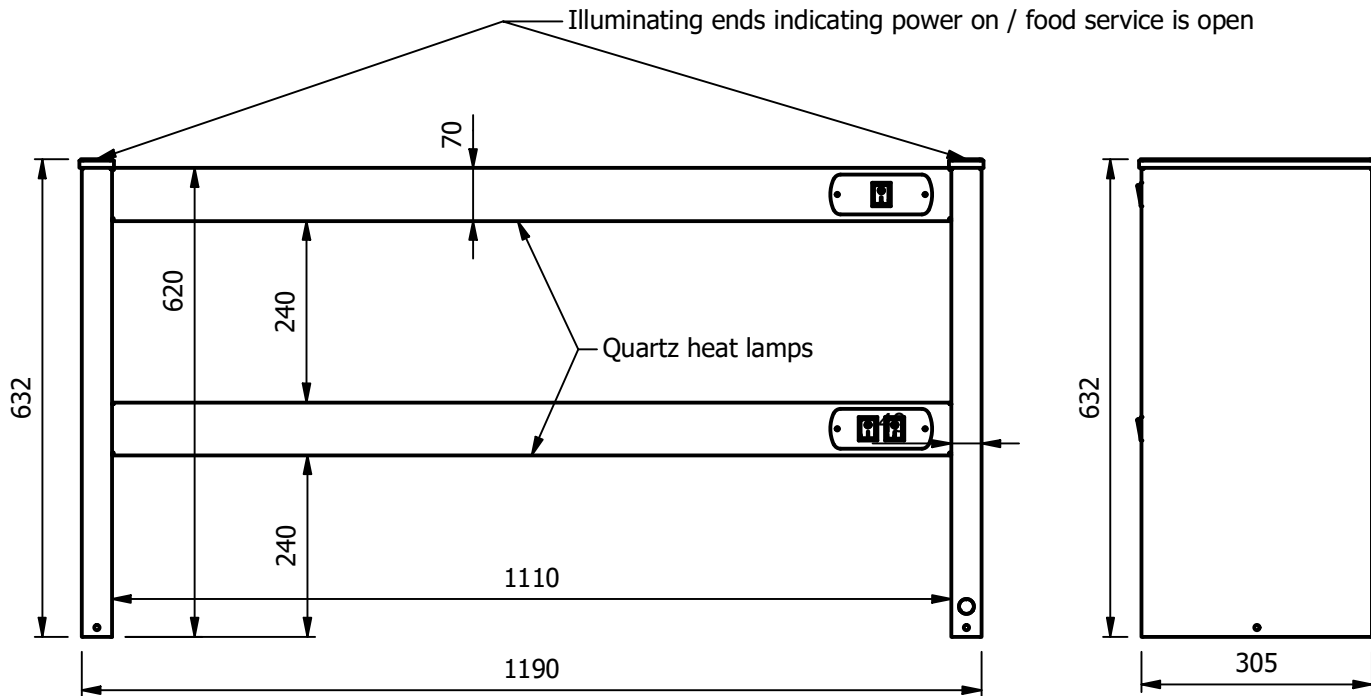

Illuminating ends indicating power on / food service is open

Quartz heat lamps

ALL SHEET METAL DIMENSIONS ARE I/S (INSIDE SIZES) (UNLESS OTHERWISE STATED)

ALL DIMENSIONS IN (mm), TOLERANCE = LINEAR ± 0.5mm, ANGULAR ± 0.5mm (OR AS STATED). ALL SHARP EDGES TO BE REMOVED FROM SHEET METAL PARTS

Product	KITCHEN PASS			Product No	 The Catering Equipment Company
Description	*** KP3H2 ***				
Material/Finish	Thickness		Desp/Date		<small>No reproduction or publication of this drawing may be made, and no article may be manufactured or assembled in accordance with this drawing without prior written consent. This prohibition is a term of any contract relating to this drawing. Rights reserved under the Copyright Act 1956 as amended by the Design Copyright Act 1968.</small>
Legacy P/N	Weight	22kg	Quote No.	Dwg No.	
Client			SO Number	STANDARD	CTRA-086375
Client Project			Approved By		Issue
E & R MOFFAT LTD, SEABEGS ROAD, BONNYBRIDGE, FK4 2BS, T: +44 (0)1324 812272, E: sales@ermoffat.co.uk, Web: www.ermoffat.co.uk					Dwg No. CTRA-086375 Drawn By ABB Date 31/03/2020 Scale 1 : 10 Sheet 1 / 2 A4