

Suitable for 1/1 Gn Pans



Moffat Specification

Dimensions

length - 1126mm
 Depth - 626mm
 Height - 950mm
 Weight - 26kg

Capacity

Shelf Area = 1040mm x 540mm [3 x 1/1 Gn type pans]
 Maximum load per shelf 60 kg

Features

Radius bottom corners and 40mm raised lip to retain load.
 Round stainless steel handle at both ends.
 All welded construction to form a heavy duty unit.
 4 Revolving buffers fitted as standard.

Materials

1.2mm 304 Grade St/ Steel Top & Supports
 Framework 30 x 30 430 grade St/Steel

Installation

All swivel castors, two braked

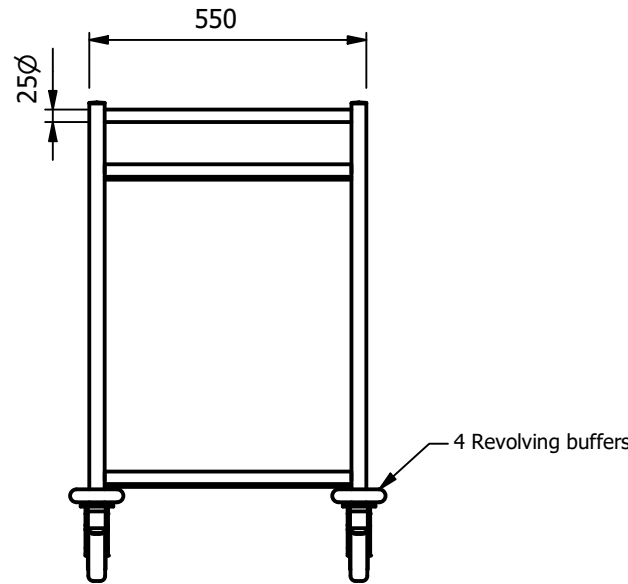
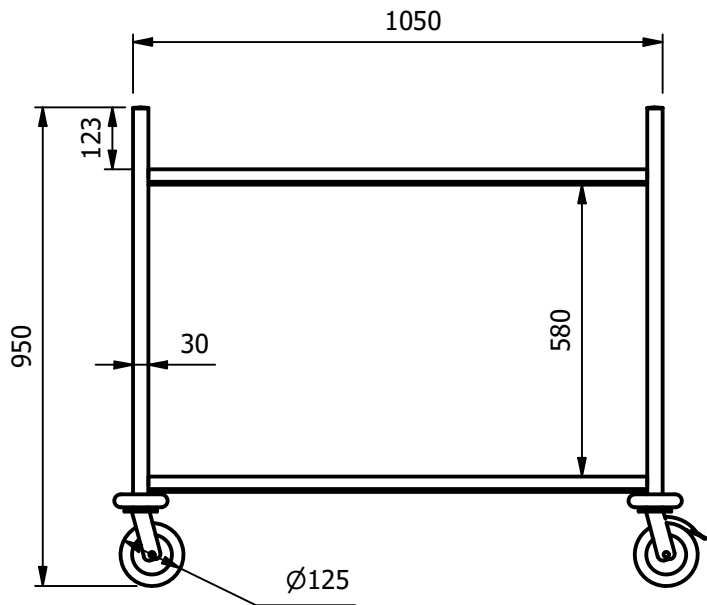

ALL SHEET METAL DIMENSIONS ARE I/S (INSIDE SIZES) (UNLESS OTHERWISE STATED)

ALL DIMENSIONS IN (mm), TOLERANCE = LINEAR ± 0.5mm, ANGULAR ± 0.5mm (OR AS STATED). ALL SHARP EDGES TO BE REMOVED FROM SHEET METAL PARTS

Product	FABRICATION			Product No			
Description	HTG2			<small>No reproduction or publication of this drawing may be made, and no article may be manufactured or assembled in accordance with this drawing without prior written consent. This prohibition is a term of any contract relating to this drawing. Rights reserved under the Copyright Act 1956 as amended by the Design Copyright Act 1968.</small>			
Material/Finish	Thickness		Desp/Date				
Legacy P/N	Weight	26kg	Quote No.	Dwg No.	WBA-074837	Issue	
Client				SO Number	STD	Drawn By	N.Raymen
Client Project				Approved By		Date	19/06/2020
E & R MOFFAT LTD, SEABEGS ROAD, BONNYBRIDGE, FK4 2BS, T: +44 (0)1324 812272, E: sales@ermoffat.co.uk, Web: www.ermoffat.co.uk				Scale	1 : 15	Sheet	1 / 1
							A4