

**Warning**  
 Do not install unit in draught conditions where the air movement is greater than 0.2mtr/sec.  
 e.g.near entrance/exit doors, open windows, under air conditioning units or a ceiling mounted fan  
 Ambient room conditions must not drop below 16°C .

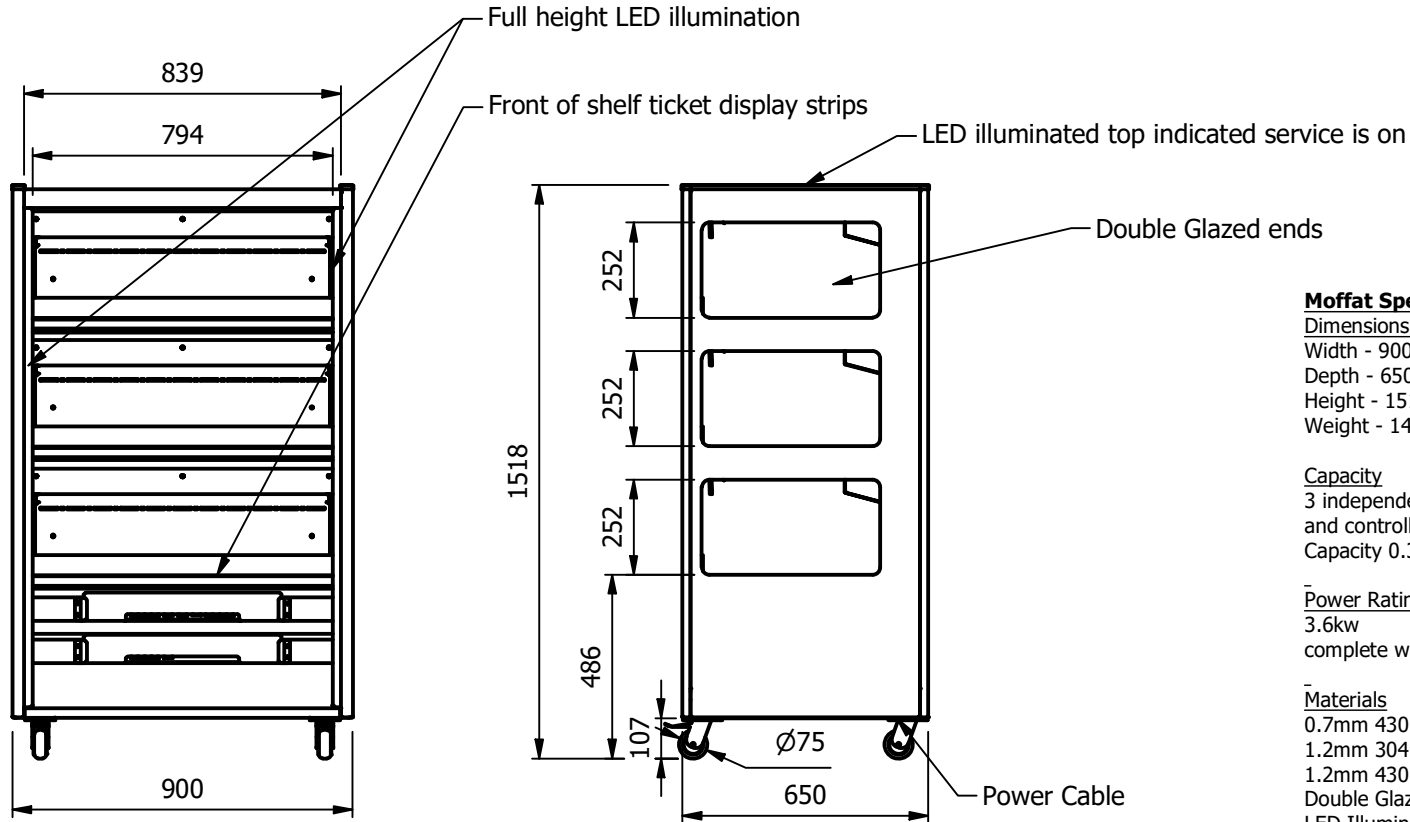
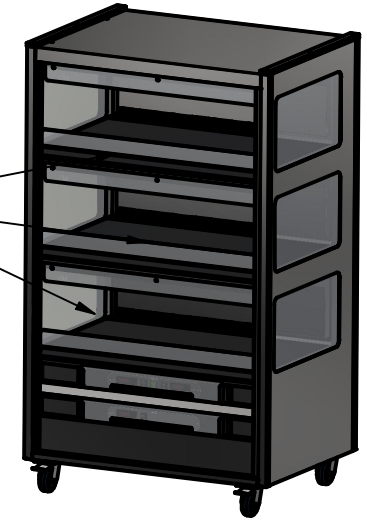

**Moffat Specification**

Dimensions

Width - 900mm  
 Depth - 650mm  
 Height - 1518mm  
 Weight - 146kg

Capacity

3 independently heated  
 and controlled shelves / zones  
 Capacity 0.30m3

Power Rating

3.6kw  
 complete with a 2m long cord set & 32amp single phase plug

Materials

0.7mm 430 Grade St/Steel inner panels  
 1.2mm 304 Grade St/ Steel structure  
 1.2mm 430 Grade St Steel Ancillary Parts  
 Double Glazed Tempered Glass  
 LED Illumination



ALL SHEET METAL DIMENSIONS ARE I/S (INSIDE SIZES) (UNLESS OTHERWISE STATED)

ALL DIMENSIONS IN (mm), TOLERANCE = LINEAR ± 0.5mm, ANGULAR ± 0.5mm (OR AS STATED). ALL SHARP EDGES TO BE REMOVED FROM SHEET METAL PARTS

Product	GO-M		Product No	N/A					
Description	GOM23								
Material/Finish	Thickness		Desp/Date			<small>No reproduction or publication of this drawing may be made, and no article may be manufactured or assembled in accordance with this drawing without prior written consent. This prohibition is a term of any contract relating to this drawing. Rights reserved under the Copyright Act 1956 as amended by the Design Copyright Act 1968.</small>			
Legacy P/N	Weight	146kg	Quote No.						
Client			SO Number	N/A		Dwg No.	GGP-159455-1	Issue	
Client Project			Approved By			Drawn By	ABB		
E & R MOFFAT LTD, SEABEGS ROAD, BONNYBRIDGE, FK4 2BS, T: +44 (0)1324 812272, E: sales@ermoffat.co.uk, Web: www.ermoffat.co.uk						Date	25/03/2025		
						Scale	1 : 20	Sheet	1 / 3
									<b>A4</b>