

Warning

Do not install unit in draught conditions where the air movement is greater than 0.2mtr/sec.
e.g.near entrance/exit doors, open windows, under air conditioning units or a ceiling mounted fan
Ambient room conditions must not drop below 16°C .

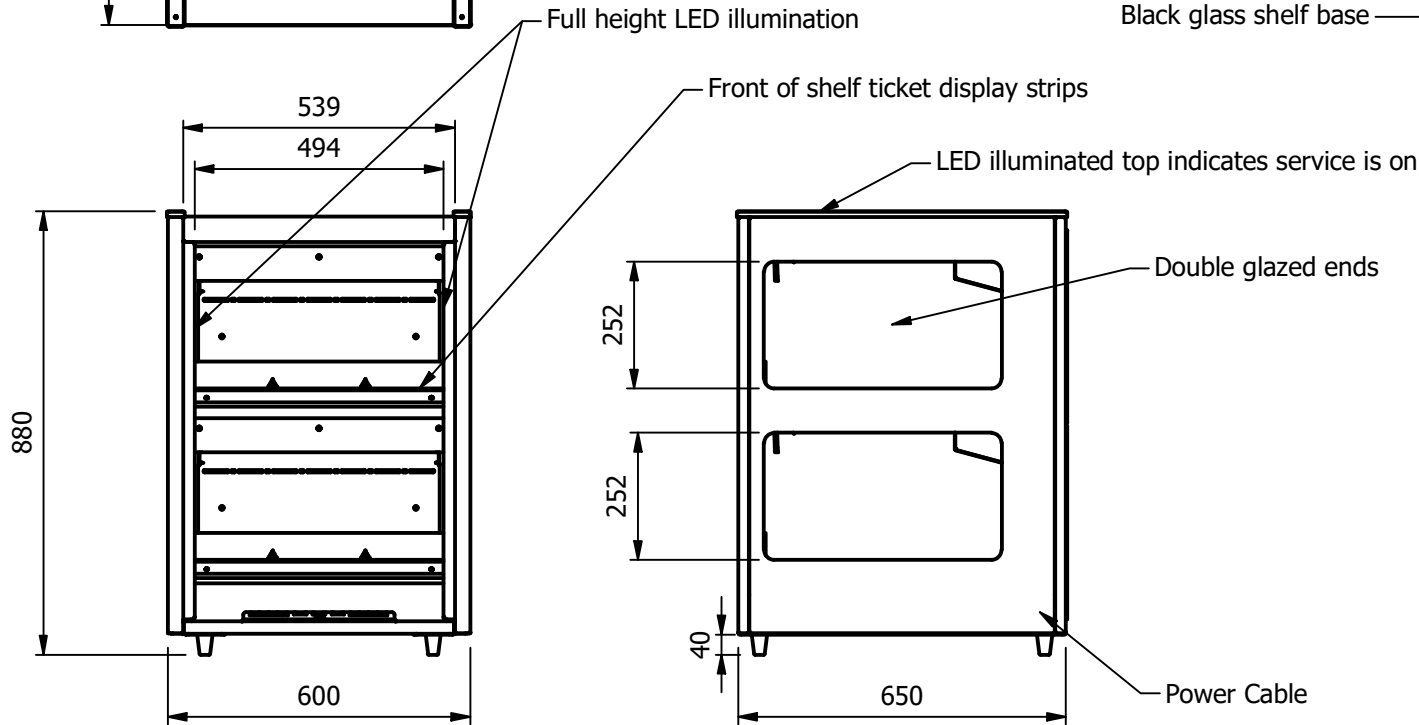
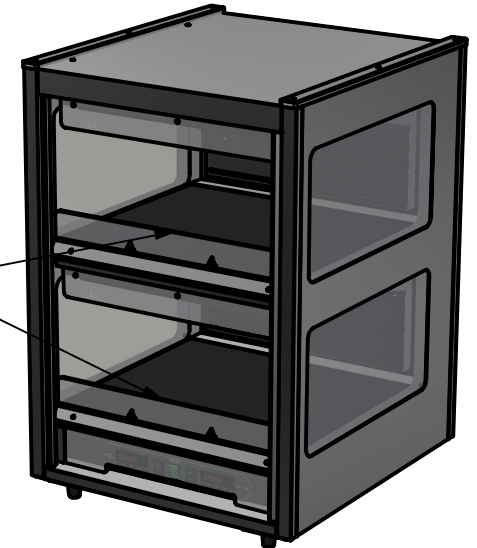

Moffat Specification

Dimensions

Width - 600mm
Depth - 650mm
Height - 880mm
Weight - 69kg

Capacity

2 independently heated
and controlled shelves / zones
Capacity 0.14m³

Power Rating

1.2kw
complete with a 2m long cord set & 13amp plug

Materials

0.7mm 430 Grade St/Steel inner panels
1.2mm 304 Grade St/ Steel structure
1.2mm 430 Grade St Steel Ancillary Parts
Double Glazed Tempered Glass
LED Illumination



ALL SHEET METAL DIMENSIONS ARE I/S (INSIDE SIZES) (UNLESS OTHERWISE STATED)

ALL DIMENSIONS IN (mm), TOLERANCE = LINEAR ± 0.5mm, ANGULAR ± 0.5mm (OR AS STATED). ALL SHARP EDGES TO BE REMOVED FROM SHEET METAL PARTS

Product	GO-M		Product No	N/A					
Description	GOM12								
Material/Finish	Thickness		Desp/Date			<small>No reproduction or publication of this drawing may be made, and no article may be manufactured or assembled in accordance with this drawing without prior written consent. This prohibition is a term of any contract relating to this drawing. Rights reserved under the Copyright Act 1956 as amended by the Design Copyright Act 1968.</small>			
Legacy P/N	Weight	69kg	Quote No.						
Client			SO Number	N/A		Dwg No.	GGP-159299-1	Issue	
Client Project			Approved By			Drawn By	ABB		
						Date	25/03/2025		
E & R MOFFAT LTD, SEABEGS ROAD, BONNYBRIDGE, FK4 2BS, T: +44 (0)1324 812272, E: sales@ermoffat.co.uk, Web: www.ermoffat.co.uk						Scale	1 : 15	Sheet	1 / 3
									A4