

**Warning**

Do not install unit in draught conditions where the air movement is greater than 0.2mtr/sec.  
e.g.near entrance/exit doors, open windows, under air conditioning units or a ceiling mounted fan  
Ambient room conditions must not drop below 16°C .

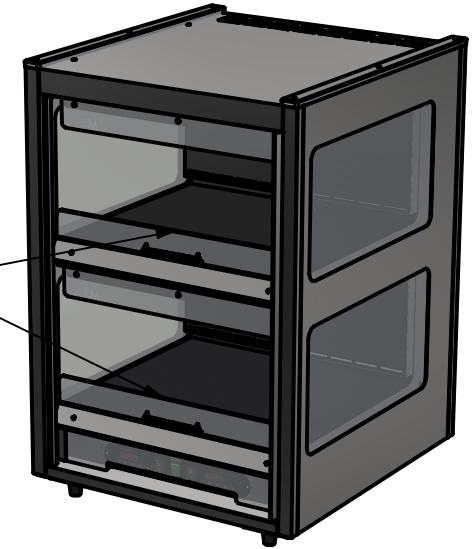

Black glass shelf base

Full height LED illumination

Front of shelf ticket display strips

LED illuminated top indicates service is on

Double glazed ends

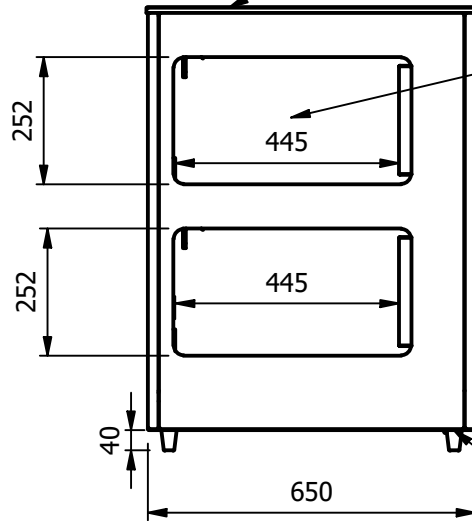
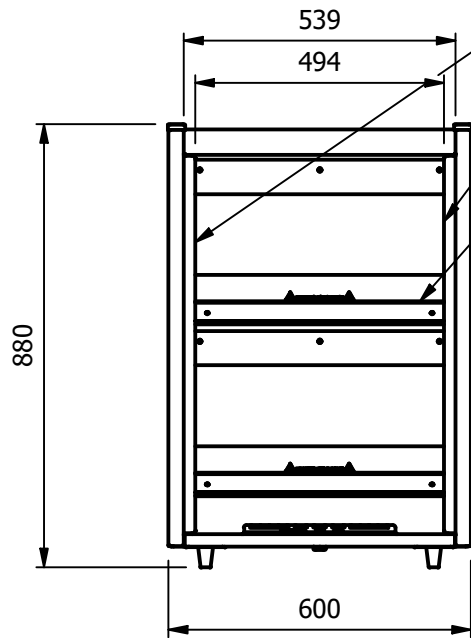

Power Cable

**Moffat Specification**

Dimensions

Width - 600mm  
Depth - 650mm  
Height - 880mm  
Weight - 69kg

Capacity

2 independently heated  
and controlled shelves / zones  
Capacity 0.12m<sup>3</sup>

Power Rating

1.5kw  
complete with a 2m long cord set & 13amp plug

Materials

0.7mm 430 Grade St/Steel inner panels  
1.2mm 304 Grade St/ Steel structure  
1.2mm 430 Grade St Steel Ancillary Parts  
Double Glazed Tempered Glass  
LED Illumination

ALL SHEET METAL DIMENSIONS ARE I/S (INSIDE SIZES) (UNLESS OTHERWISE STATED)

ALL DIMENSIONS IN (mm), TOLERANCE = LINEAR ± 0.5mm, ANGULAR ± 0.5mm (OR AS STATED). ALL SHARP EDGES TO BE REMOVED FROM SHEET METAL PARTS

Product	MERCHANDISER			Product No	N/A				
Description	GO12			<small>No reproduction or publication of this drawing may be made, and no article may be manufactured or assembled in accordance with this drawing without prior written consent. This prohibition is a term of any contract relating to this drawing. Rights reserved under the Copyright Act 1956 as amended by the Design Copyright Act 1968.</small>					
Material/Finish	Thickness		Desp/Date						
Legacy P/N	Weight	69kg	Quote No.		Dwg No.	VCP-136726-1	Issue		
Client			SO Number	N/A	Drawn By	ABB	-		
Client Project			Approved By		Date	01/10/2021			
E & R MOFFAT LTD, SEABEGS ROAD, BONNYBRIDGE, FK4 2BS, T: +44 (0)1324 812272, E: sales@ermoffat.co.uk, Web: www.ermoffat.co.uk					Scale	1 : 15	Sheet	1 / 3	<b>A4</b>