

Neo-Ceram Hot Top Area

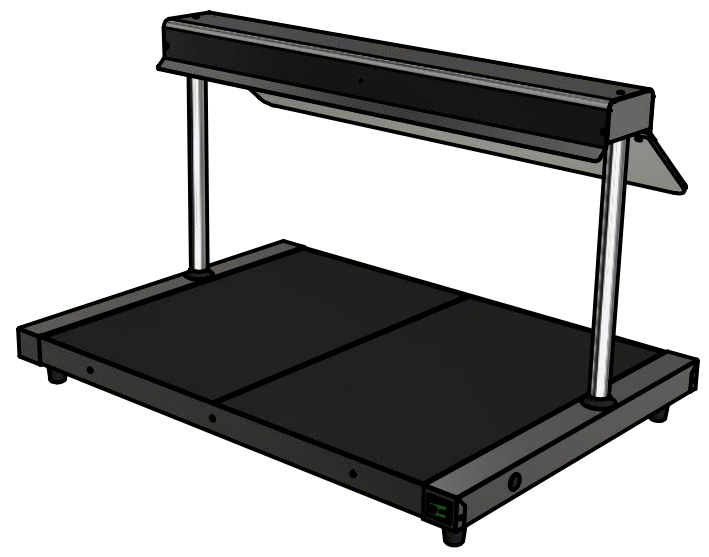

Moffat Specification

Hot Top
Neo-Ceram glass hot plates self regulating at approximately 95°C With quartz illuminated and heated overhead gantry.

Dimensions
Width - 750mm
Depth - 539mm
Height - 475mm (80mm to serving Top)
Weight - 18kg

Power Rating
0.58 kw
complete with a 2m long cord set & 13amp plug

Materials
0.7mm 430 Grade St/Steel
1.2mm 430 Grade St Steel Ancillary Parts
4mm Neo-Ceram Hot Plates

Installation
Table Top

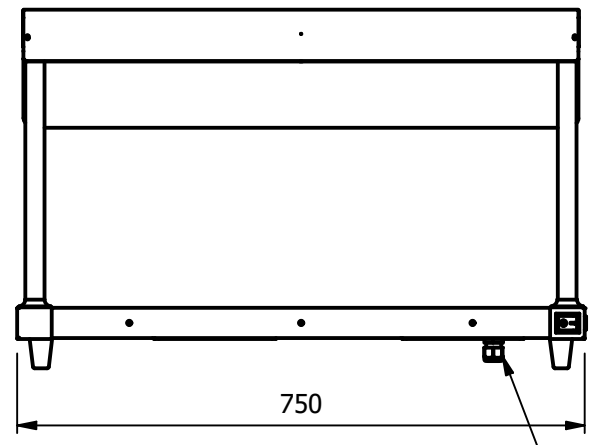

Power outlet

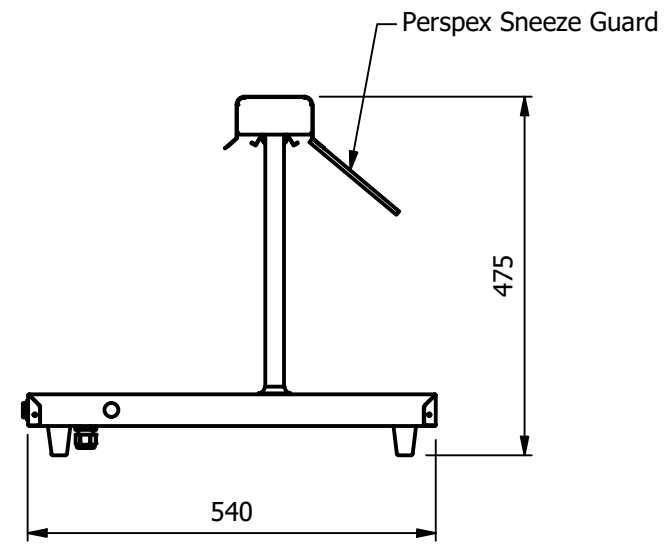

ALL SHEET METAL DIMENSIONS ARE I/S (INSIDE SIZES) (UNLESS OTHERWISE STATED)

ALL DIMENSIONS IN (mm), TOLERANCE = LINEAR ± 0.5mm, ANGULAR ± 0.5mm (OR AS STATED). ALL SHARP EDGES TO BE REMOVED FROM SHEET METAL PARTS

Product	FOCUS TOPS			Product No							
Description	FTG2										
Material/Finish	Thickness			Desp/Date							
Legacy P/N	Weight	18kg		Quote No.			Dwg No.	VCP-094057-1	Issue		
Client				SO Number	STANDARD		Drawn By	N.Raymen			
Client Project				Approved By			Date	11/06/2021			
E & R MOFFAT LTD, SEABEGS ROAD, BONNYBRIDGE, FK4 2BS, T: +44 (0)1324 812272, E: sales@ermoffat.co.uk, Web: www.ermoffat.co.uk							Scale	1 : 10	Sheet	1 / 2	A4

No reproduction or publication of this drawing may be made, and no article may be manufactured or assembled in accordance with this drawing without prior written consent. This prohibition is a term of any contract relating to this drawing. Rights reserved under the Copyright Act 1956 as amended by the Design Copyright Act 1968.