

Moffat Specification

Dimensions

Length - 1800mm
 Depth - 650mm
 Height - 900mm
 Weight - 60kg

Capacity of Hot Cupboard [usable inside space]

length - 1697mm
 Depth - 538mm
 The Mid shelf is removable and adjustable to three positions

84 covers & meals [10" plated meals stacked using plate covers]
 or
 252 off 10" plates stacked for heating
 or
 15 off 1/1GN pans side by side 150mm deep
 (4 on top shelf, 8 on bottom shelf stacked)

Materials

1.2mm 304 Grade St/ Steel Top & Supports
 0.7mm 430 Grade St/ Steel Internal Structure
 GN 1/1 Grid Shelves with 30mm x 30mm tube supports

Installation

All swivel castors, two braked

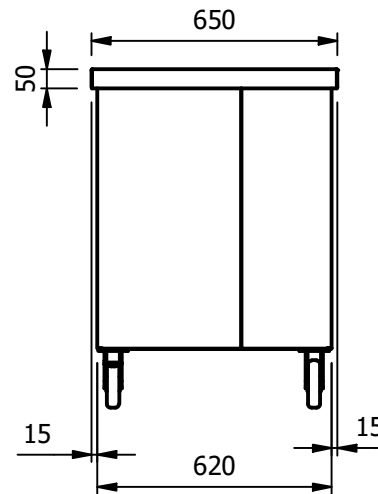
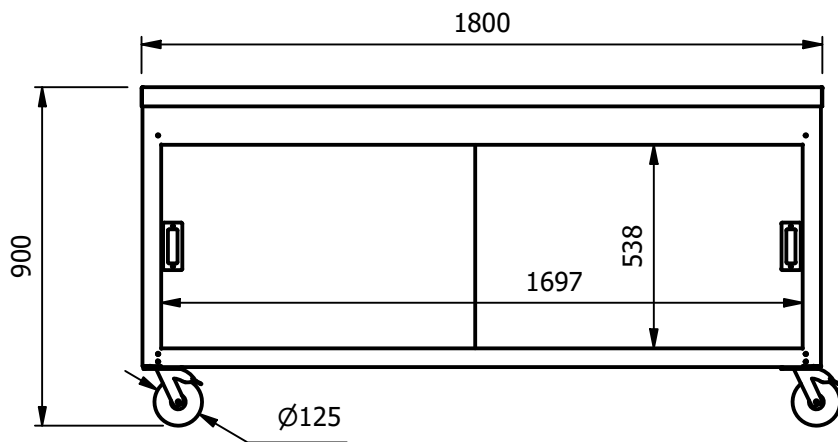

ALL SHEET METAL DIMENSIONS ARE I/S (INSIDE SIZES) (UNLESS OTHERWISE STATED)

ALL DIMENSIONS IN (mm), TOLERANCE = LINEAR ± 0.5mm, ANGULAR ± 0.5mm (OR AS STATED). ALL SHARP EDGES TO BE REMOVED FROM SHEET METAL PARTS

Product	FOCUS			Product No							
Description	*** FCC1865 ***			<small>© No reproduction or publication of this drawing may be made, and no article may be manufactured or assembled in accordance with this drawing without prior written consent. This prohibition is a term of any contract relating to this drawing. Rights reserved under the Copyright Act 1956 as amended by the Design Copyright Act 1968.</small>							
Material/Finish	Thickness			Desp/Date							
Legacy P/N	Weight	60kg		Quote No.	Dwg No.	UMA-088584-1	Issue				
Client				SO Number	STANDARD		Drawn By	N.Raymen			
Client Project				Approved By			Date	01/03/2021			
E & R MOFFAT LTD, SEABEGS ROAD, BONNYBRIDGE, FK4 2BS, T: +44 (0)1324 812272, E: sales@ermoffat.co.uk, Web: www.ermoffat.co.uk							Scale	1 : 20	Sheet	1 / 2	A4