

Important Design Parameters

Allowances must be made for air venting.

The under slung compressor must have an unrestricted air flow.

Proper venting must be provided ensuring cool air from the room can be drawn in through the condensing coil and out the other side.

The 'Plenum Duct' supplied should be fitted between the unit & the shop-fitted counter panels.

Warning

Do not install unit in draughty conditions where the air movement is greater than 0.2mtr/sec.

e.g.near entrance/exit doors, open windows, under air conditioning units or a ceiling mounted fan

Do not install units where there is high radiated heat, e.g. direct sunlight, room heaters, or bright spot lights.

Ambient room conditions must not exceed 25°C or a relative humidity of 60%.

Blocked vents will cause reduced refrigeration efficiency and lead to malfunction

Alternative Vent Panel Routing

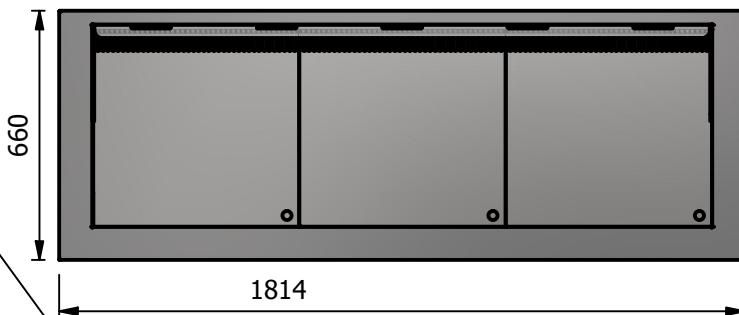
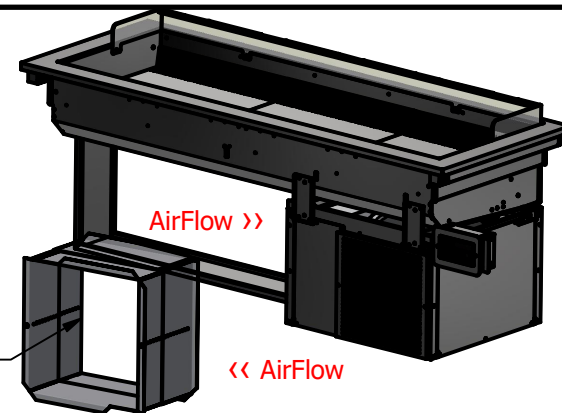
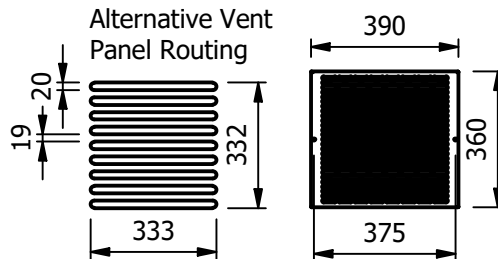

Important
Position of air intake vent
This area must be clear for air flow

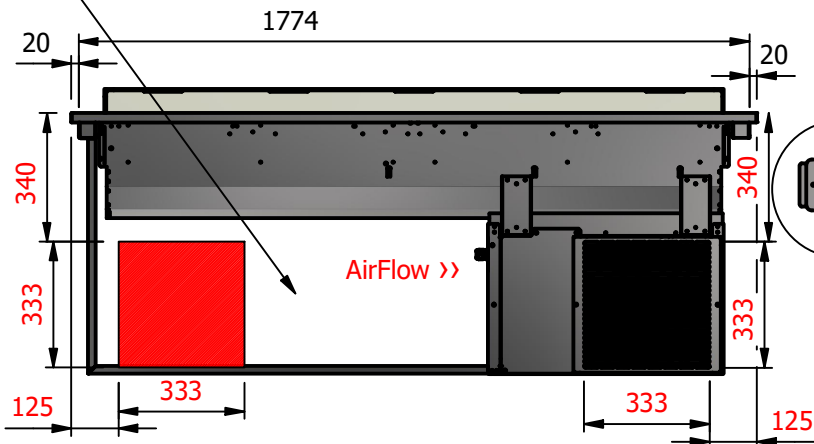
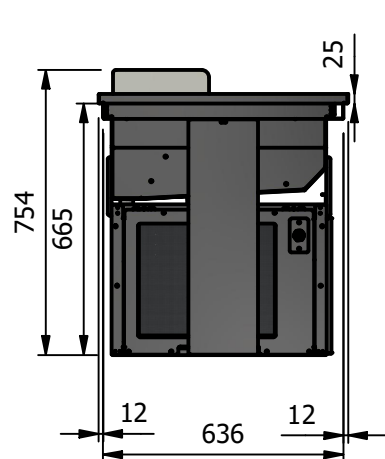

Rear View
[Operators Side]

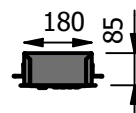

Panel Mounted Control Box

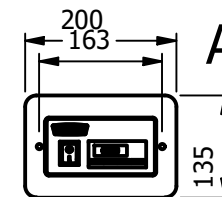

A (1 : 10)

Moffat Specification

Dimensions

Width - 1814mm

Depth - 660mm

Height - 754mm

Weight - 93kg

Well - 1640mm x 535mm x 130mm

Power Rating

2.0 kw

complete with a 2m long cord set & 13amp plug

Materials

0.7mm 430 Grade St/Steel Gantry Hood

1.2mm 304 Grade St/ Steel Top & Supports

1.2mm 430 Grade St Steel Ancillary Parts

1.2mm Galvanised Steel Inner Supports

6mm Tempered Glass

LED Illumination

Installation

Counter Top Flush Fit Cut Out Dimensions

1820mm x 666mm x 25mm

Counter Support Cut Out Dimensions

1796mm x 642mm

Control Box

Panel Mounted Cut Out Dimension

185mm x 120mm

2m Long Power Cable Connecting

Control Box to Base unit

ALL SHEET METAL DIMENSIONS ARE I/S (INSIDE SIZES) (UNLESS OTHERWISE STATED)

ALL DIMENSIONS IN (mm), TOLERANCE = LINEAR ± 0.5mm, ANGULAR ± 0.5mm (OR AS STATED). ALL SHARP EDGES TO BE REMOVED FROM SHEET METAL PARTS

Product	DROP-IN RANGE			Product No	 The Catering Equipment Company			
Description	D5RWNG							
Material/Finish	Thickness		Desp/Date		No reproduction or publication of this drawing may be made, and no article may be manufactured or assembled in accordance with this drawing without prior written consent. This prohibition is a term of any contract relating to this drawing. Rights reserved under the Copyright Act 1956 as amended by the Design Copyright Act 1968.			
Legacy P/N	Weight	93kg	Quote No.					
Client			SO Number	N/A	Dwg No.	DIP-034618	Issue	
Client Project			Approved By		Drawn By	ABB		
					Date	22/05/2019		
E & R MOFFAT LTD, SEABEGS ROAD, BONNYBRIDGE, FK4 2BS, T: +44 (0)1324 812272, E: sales@ermoffat.co.uk, Web: www.ermoffat.co.uk					Scale	1:20	Sheet	1 / 1