

**Important Design Parameters**

On the operators side of the Servery Counter a removable service panel is required to allow access to service heating elements etc. The dimensions of the access aperture must be no less than 1653mm x 145mm.

Additionally access is required to manually operate the drain valve. Drain connection is via 15mm lever ball valve.

**Warning**

The unit must be manually filled with water. Capacity 33 litre. A depth of 40mm must be maintained during operation. [water level marker fitted to element cover]

**Moffat Specification**

Wet Heat  
Immersion heated Bainmarie Well

Dimensions  
Width - 1814mm  
Depth - 660mm  
Height - 666mm  
Weight - 67kg

Power Rating  
5.88kw  
complete with a 2m long cord set & 32amp plug

Materials  
1.2mm 304 Grade St/ Steel Top, Supports & Well  
0.7mm 430 Grade St/ Steel External Structure  
0.7mm Galvanised Steel Undercarrage  
6mm Tempered Glass  
Quartz Lamps

Installation  
Counter Top Flush Fit Cut Out Dimensions  
1820mm x 666mm x 25mm  
Counter Support Cut Out Dimensions  
1796mm x 642mm

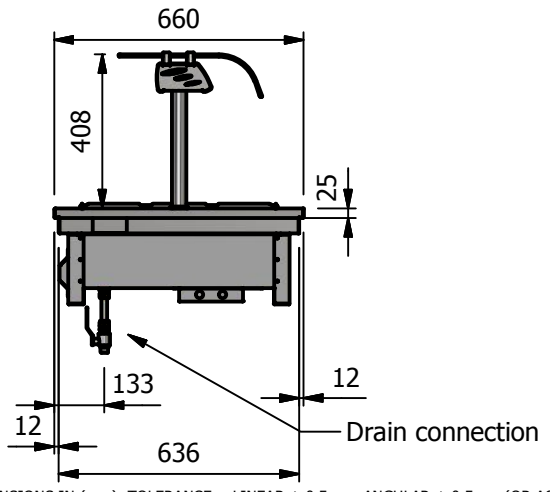
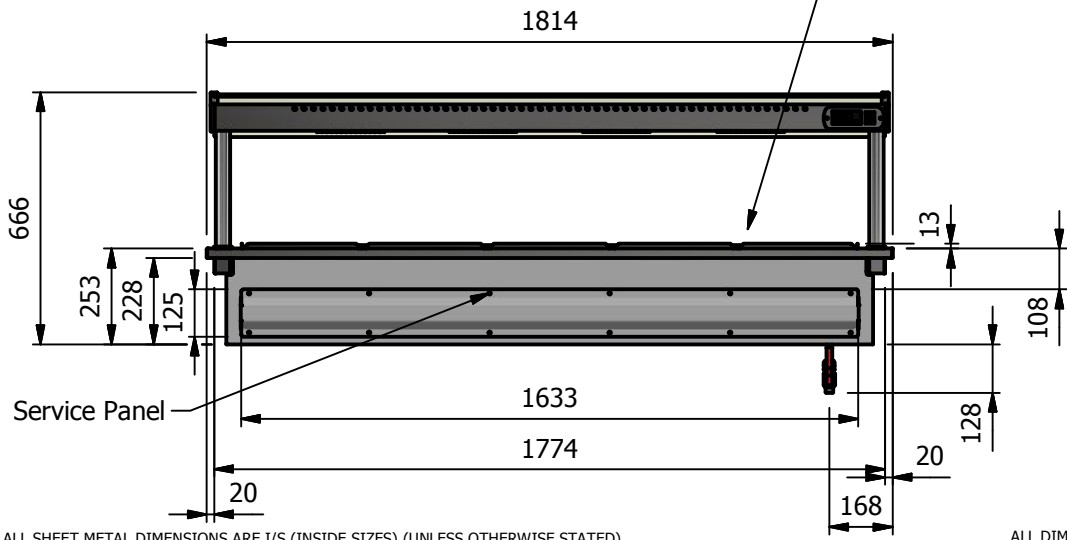

ALL SHEET METAL DIMENSIONS ARE 1/8" (INSIDE SIZES) (UNLESS OTHERWISE STATED) ALL DIMENSIONS IN (mm), TOLERANCE = LINEAR ± 0.5mm, ANGULAR ± 0.5mm (OR AS STATED). ALL SHARP EDGES TO BE REMOVED FROM SHEET METAL PARTS

Product	DROP-IN RANGE			Product No		<p>The Catering Equipment Company</p>			
Description	D5BMW								
Material/Finish	Thickness			Desp/Date		<p>No reproduction or publication of this drawing may be made, and no article may be manufactured or assembled in accordance with this drawing without prior written consent. This prohibition is a term of any contract relating to this drawing. Rights reserved under the Copyright Act 1956 as amended by the Design Copyright Act 1968.</p>			
Legacy P/N	Weight	67kg		Quote No.					
Client				SO Number	N/A	Dwg No.	DIP-022415	Issue	
Client Project				Approved By		Drawn By	ABB		
						Date	16/01/2019		