

Moffat Specification

Dry Heat
Fan Assisted Bainmarie Well

Dimensions
Width - 1814mm
Depth - 660mm
Height - 701mm
Weight - 57kg

Power Rating
2.78kw
complete with a 2m long cord set & 13amp plug
Removable Fan heating System Sahara Fan Model SF319

Materials
1.2mm 304 Grade St/ Steel Top & Supports
0.7mm 430 Grade St/ Steel Internal Structure
0.7mm Galvanised Steel Undercarrage
6mm Tempered Glass
Quartz Lamps

Installation
Counter Top Flush Fit Cut Out Dimensions
1820mm x 666mm x 25mm
Counter Support Cut Out Dimensions
1796mm x 642mm

Sahara Fan Model SF319

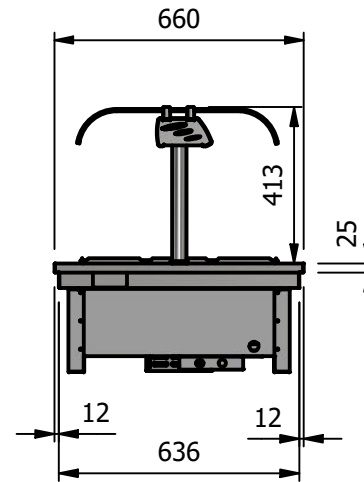
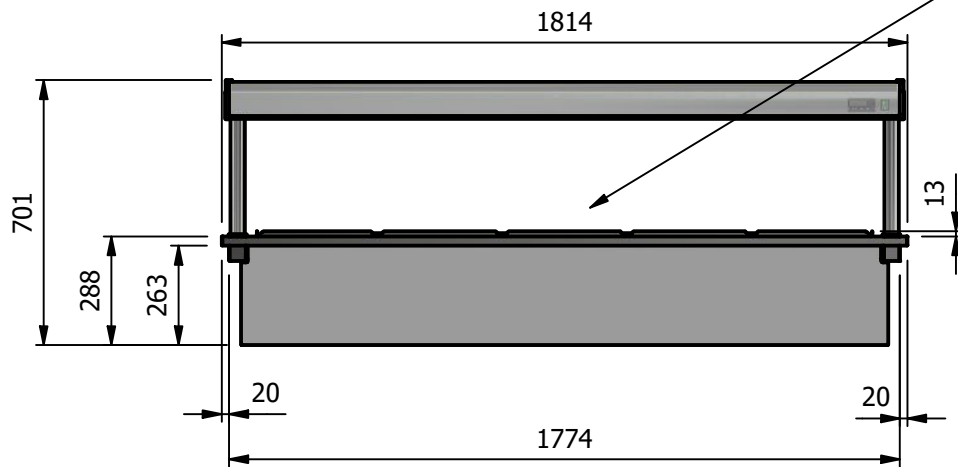

ALL SHEET METAL DIMENSIONS ARE I/S (INSIDE SIZES) (UNLESS OTHERWISE STATED)

ALL DIMENSIONS IN (mm), TOLERANCE = LINEAR ± 0.5mm, ANGULAR ± 0.5mm (OR AS STATED). ALL SHARP EDGES TO BE REMOVED FROM SHEET METAL PARTS

Product	DROP-IN RANGE			Product No	 The Catering Equipment Company				
Description	D5BMI								
Material/Finish	Thickness		Desp/Date		<small>No reproduction or publication of this drawing may be made, and no article may be manufactured or assembled in accordance with this drawing without prior written consent. This prohibition is a term of any contract relating to this drawing. Rights reserved under the Copyright Act 1956 as amended by the Design Copyright Act 1968.</small>				
Legacy P/N	Weight	57kg	Quote No.	Dwg No.					
Client			SO Number	N/A	DIP-113564				
Client Project			Approved By		Issue				
E & R MOFFAT LTD, SEABEGS ROAD, BONNYBRIDGE, FK4 2BS, T: +44 (0)1324 812272, E: sales@ermoffat.co.uk, Web: www.ermoffat.co.uk					Drawn By ABB Date 16/01/2019				
					Scale	1:20	Sheet	1 / 2	A4