

Moffat Specification

Dry Heat
Fan Assisted Bainmarie Well

Dimensions
Width - 1814mm
Depth - 660mm
Height - 701mm
Weight - 57kg

Power Rating
2.78kw
complete with a 2m long cord set & 13amp plug
Removable Fan heating System Sahara Fan Model SF319

Materials
1.2mm 304 Grade St/ Steel Top & Supports
0.7mm 430 Grade St/ Steel Internal Structure
0.7mm Galvanised Steel Undercarrage
6mm Tempered Glass
Quartz Lamps

Installation
Counter Top Flush Fit Cut Out Dimensions
1820mm x 666mm x 25mm
Counter Support Cut Out Dimensions
1796mm x 642mm

Sahara Fan Model SF319

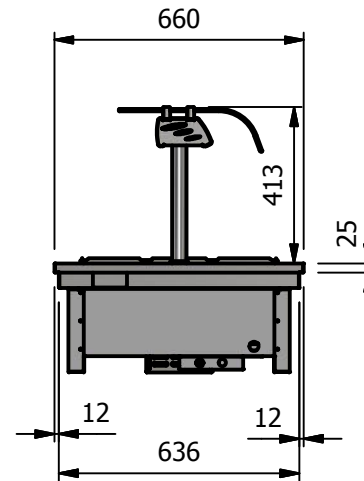
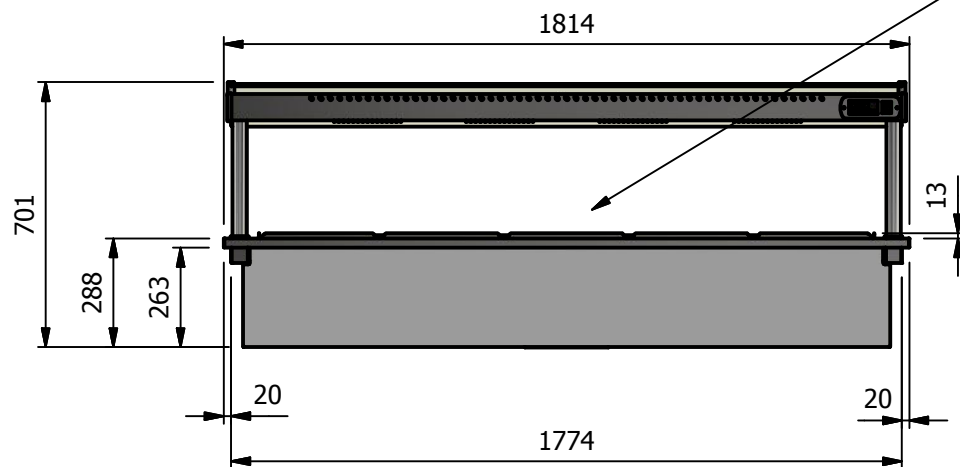

ALL SHEET METAL DIMENSIONS ARE I/S (INSIDE SIZES) (UNLESS OTHERWISE STATED)

ALL DIMENSIONS IN (mm), TOLERANCE = LINEAR ± 0.5mm, ANGULAR ± 0.5mm (OR AS STATED). ALL SHARP EDGES TO BE REMOVED FROM SHEET METAL PARTS

Product	DROP-IN RANGE			Product No		 The Catering Equipment Company	<small>No reproduction or publication of this drawing may be made, and no article may be manufactured or assembled in accordance with this drawing without prior written consent. This prohibition is a term of any contract relating to this drawing. Rights reserved under the Copyright Act 1956 as amended by the Design Copyright Act 1968.</small>		
Description	D5BM			Desp/Date			Dwg No. DIP-020685 Issue -		
Material/Finish	Thickness			Quote No.					
Legacy P/N	Weight	57kg		SO Number	N/A	Drawn By ABB Date 16/01/2019	Scale 1:20 Sheet 1 / 2 A4		
Client				Approved By					
Client Project									