

Important Design Parameters

Allowances must be made for air venting.  
 The under slung compressor must have an unrestricted air flow.  
 Proper venting must be provided ensuring cool air from the room can be drawn in through the condensing coil and out the other side.  
 The 'Plenum Duct' supplied should be fitted between the unit & the shop-fitted counter panels.

Warning

Do not install unit in draughty conditions where the air movement is greater than 0.2mtr/sec.  
 e.g. near entrance/exit doors, open windows, under air conditioning units or a ceiling mounted fan  
 Do not install units where there is high radiated heat, e.g. direct sunlight, room heaters, or bright spot lights.  
 Ambient room conditions must not exceed 25°C or a relative humidity of 60%.  
 Blocked vents will cause reduced refrigeration efficiency and lead to malfunction

Drain with valve below.  
 Connect into the main drain,  
 or placed a vessel under  
 to catch excess water

**Important**  
 Position of air intake vent  
 This area must be clear for air flow

Alternative Vent  
 Panel Routing

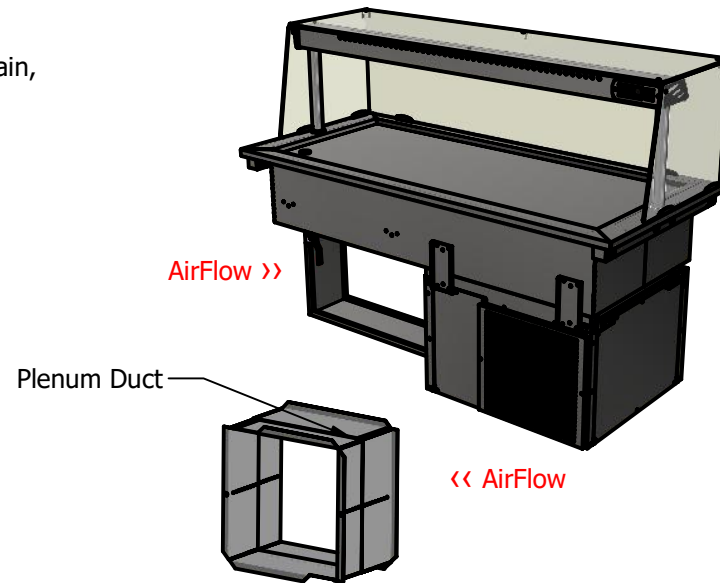
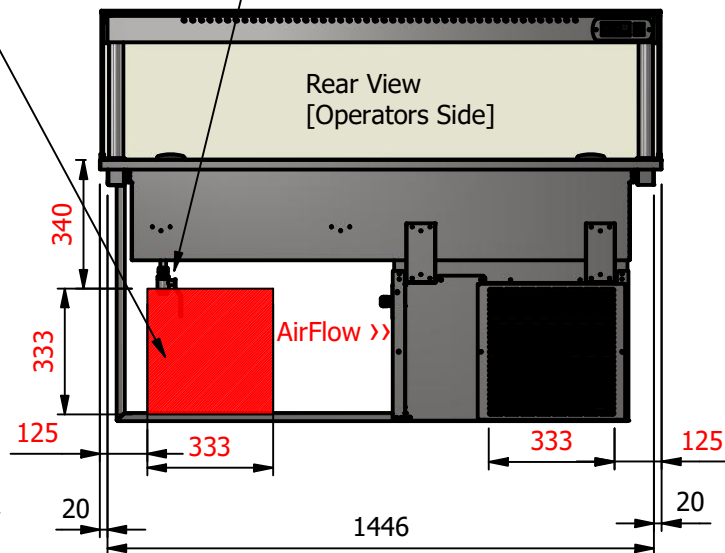
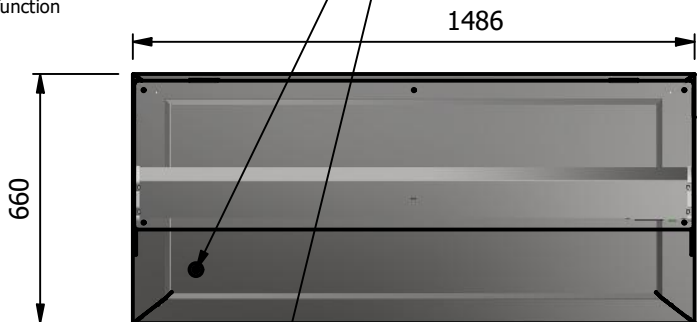
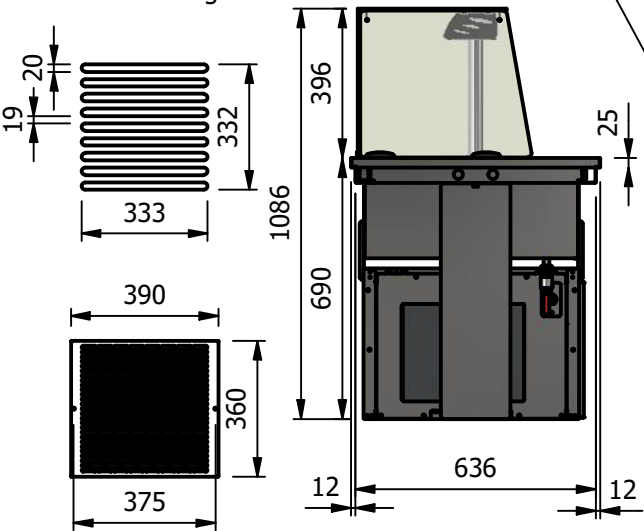

**Moffat Specification**

- Dimensions
- Width - 1486mm
- Depth - 660mm
- Height - 1086mm
- Weight - 95kg
- Recess chilled area - 1314mm x 528mm
- Power Rating
- 1.0 kw
- complete with a 2m long cord set & 13amp plug
- Materials
- 0.7mm 430 Grade St/Steel Gantry Hood
- 1.2mm 304 Grade St/ Steel Top & Supports
- 1.2mm 430 Grade St Steel Ancillary Parts
- 1.2mm Galvanised Steel Inner Supports
- 6mm Tempered Glass
- LED Illumination
- Installation
- Counter Top Flush Fit Cut Out Dimensions  
1492mm x 666mm x 25mm
- Counter Support Cut Out Dimensions  
1468mm x 642mm

ALL SHEET METAL DIMENSIONS ARE I/S (INSIDE SIZES) (UNLESS OTHERWISE STATED) ALL DIMENSIONS IN (mm), TOLERANCE = LINEAR ± 0.5mm, ANGULAR ± 0.5mm (OR AS STATED). ALL SHARP EDGES TO BE REMOVED FROM SHEET METAL PARTS

Product	DROP-IN RANGE			Product No					
Description	D4FTSLF								
Material/Finish	Thickness		Desp/Date						
Legacy P/N	Weight	95kg	Quote No.						
Client			SO Number	STANDARD	Dwg No.	DIP-101739-1	Issue		
Client Project			Approved By		Drawn By	N.Raymen			
					Date	26/08/2021			
E & R MOFFAT LTD, SEABEGS ROAD, BONNYBRIDGE, FK4 2BS, T: +44 (0)1324 812272, E: sales@ermoffat.co.uk, Web: www.ermoffat.co.uk					Scale	1 : 20	Sheet	1 / 2	<b>A4</b>

No reproduction or publication of this drawing may be made, and no article may be manufactured or assembled in accordance with this drawing without prior written consent. This prohibition is a term of any contract relating to this drawing. Rights reserved under the Copyright Act 1956 as amended by the Design Copyright Act 1968.