

Important Design Parameters

On the operators side of the Servery Counter a removable service panel is required to allow access to service heating elements etc. The dimensions of the access aperture must be no less than 1325mm x 145mm.

Additionally access is required to manually operate the drain valve. Drain connection is via 15mm lever ball valve.

Warning

The unit must be manually filled with water. Capacity 27 litre
A depth of 40mm must be maintained during operation.
[water level marker fitted to element cover]

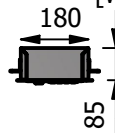

Panel Mounted Control Box

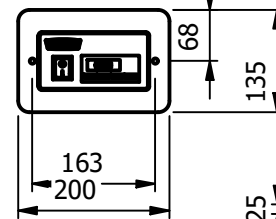

A (1 : 10)

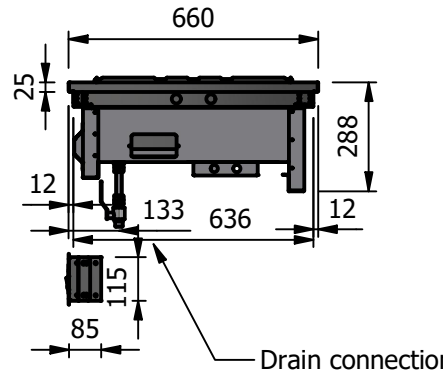
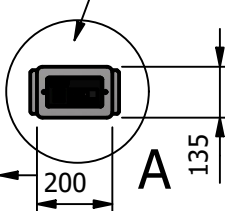

Moffat Specification

Wet Heat

Immersion heated Bainmarie Well

Dimensions

Width - 1486mm
Depth - 660mm
Height - 301mm
Weight - 44kg



Power Rating

4kw
complete with a 2m long cord set & 32amp plug

Materials

1.2mm 304 Grade St/ Steel Top, Supports & Well
0.7mm 430 Grade St/ Steel External Structure
0.7mm Galvanised Steel Undercarrage

Installation

Counter Top Flush Fit Cut Out Dimensions
1492mm x 666mm x 25mm
Counter Support Cut Out Dimensions
1468mm x 642mm

Control Box

Panel Mounted Cut Out Dimension
185mm x 120mm
2m Long Power Cable Connecting
Control Box to Base unit

ALL SHEET METAL DIMENSIONS ARE I/S (INSIDE SIZES) (UNLESS OTHERWISE STATED)

ALL DIMENSIONS IN (mm), TOLERANCE = LINEAR ± 0.5mm, ANGULAR ± 0.5mm (OR AS STATED). ALL SHARP EDGES TO BE REMOVED FROM SHEET METAL PARTS

Product	DROP-IN RANGE			Product No	 The Catering Equipment Company	
Description	D4BMWNG					
Material/Finish	Thickness		Desp/Date		<small>No reproduction or publication of this drawing may be made, and no article may be manufactured or assembled in accordance with this drawing without prior written consent. This prohibition is a term of any contract relating to this drawing. Rights reserved under the Copyright Act 1956 as amended by the Design Copyright Act 1968.</small>	
Legacy P/N	Weight	44kg	Quote No.	Dwg No.		
Client			SO Number	N/A	DIP-022426	
Client Project			Approved By		Issue	
E & R MOFFAT LTD, SEABEGS ROAD, BONNYBRIDGE, FK4 2BS, T: +44 (0)1324 812272, E: sales@ermoffat.co.uk, Web: www.ermoffat.co.uk					Drawn By ABB Date 16/01/2019	
					Scale	1:20
					Sheet	1 / 2
						A4