

Important Design Parameters

On the operators side of the Servery Counter a removable service panel is required to allow access to service heating elements etc. The dimensions of the access aperture must be no less than 1325mm x 145mm.

Additionally access is required to manually operate the drain valve. Drain connection is via 15mm lever ball valve.

Warning

The unit must be manually filled with water. Capacity 27 litre
A depth of 40mm must be maintained during operation.
[water level marker fitted to element cover]

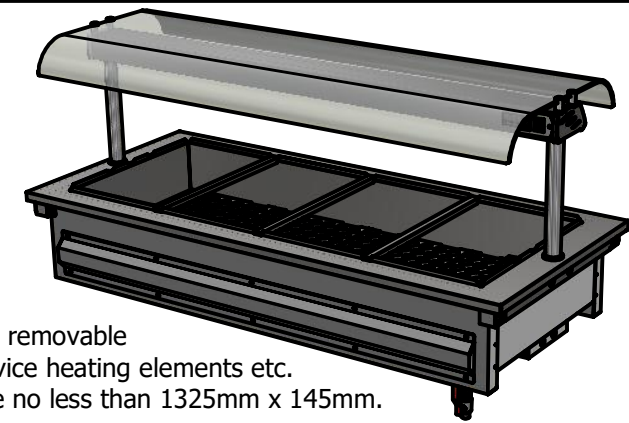
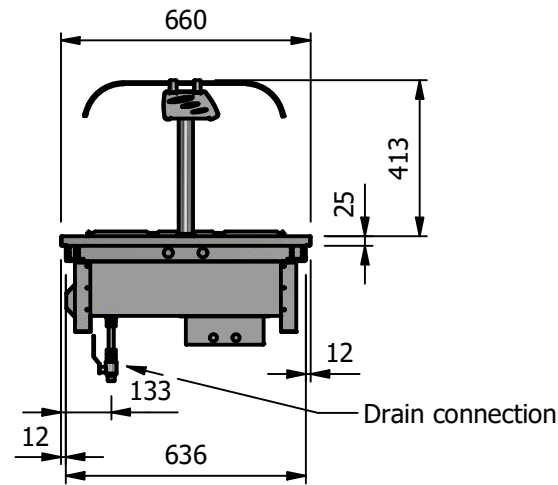

Moffat Specification

- **Wet Heat**
Immersion heated Bainmarie Well
- **Dimensions**
Width - 1486mm
Depth - 660mm
Height - 666mm
Weight - 55kg
- **Power Rating**
4.66kw
complete with a 2m long cord set & 32amp plug
- **Materials**
1.2mm 304 Grade St/ Steel Top, Supports & Well
0.7mm 430 Grade St/ Steel External Structure
0.7mm Galvanised Steel Undercarrage
6mm Tempered Glass
Quartz Lamps
- **Installation**
Counter Top Flush Fit Cut Out Dimensions
1492mm x 666mm x 25mm
Counter Support Cut Out Dimensions
1468mm x 642mm

ALL SHEET METAL DIMENSIONS ARE I/S (INSIDE SIZES) (UNLESS OTHERWISE STATED)

ALL DIMENSIONS IN (mm), TOLERANCE = LINEAR ± 0.5mm, ANGULAR ± 0.5mm (OR AS STATED). ALL SHARP EDGES TO BE REMOVED FROM SHEET METAL PARTS

Product	DROP-IN RANGE			Product No			
Description	D4BMW1						
Material/Finish	Thickness			Desp/Date			
Legacy P/N	Weight	55kg		Quote No.			
Client				SO Number	N/A		 The Catering Equipment Company
Client Project				Approved By			
				Dwg No.	DIP-113575		Issue
				Drawn By	ABB		-
				Date	16/01/2019		
E & R MOFFAT LTD, SEABEGS ROAD, BONNYBRIDGE, FK4 2BS, T: +44 (0)1324 812272, E: sales@ermoffat.co.uk, Web: www.ermoffat.co.uk				Scale	1:20		Sheet
							1 / 2
							A4

No reproduction or publication of this drawing may be made, and no article may be manufactured or assembled in accordance with this drawing without prior written consent. This prohibition is a term of any contract relating to this drawing. Rights reserved under the Copyright Act 1956 as amended by the Design Copyright Act 1968.