

Sahara Fan Model SF315

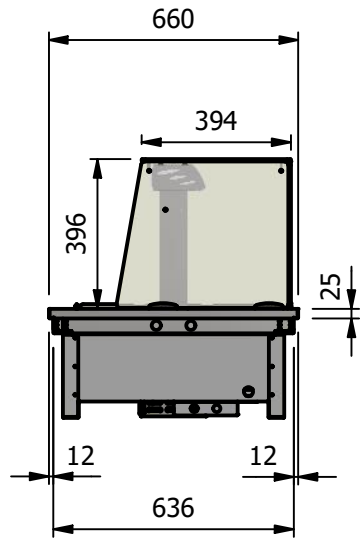
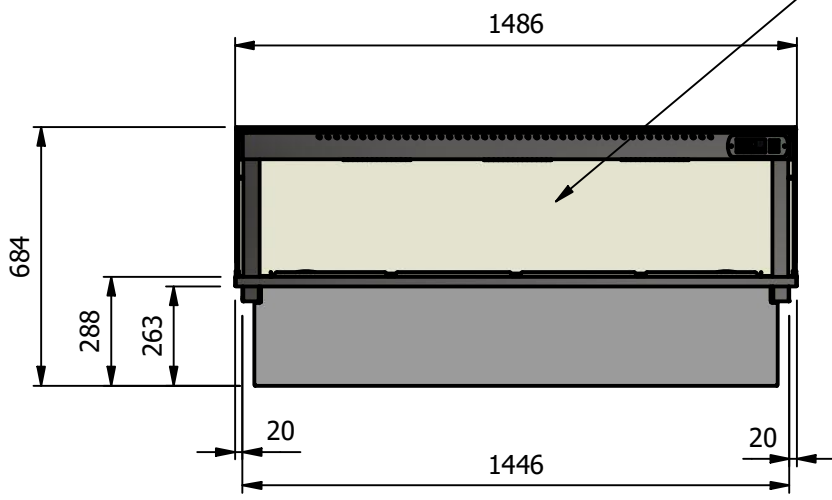

**Moffat Specification**

Dry Heat  
Fan Assisted Bainmarie Well

Dimensions  
Width - 1486mm  
Depth - 660mm  
Height - 684mm  
Weight - 67kg

Power Rating  
2.16kw  
complete with a 2m long cord set & 13amp plug  
Removable Fan heating System Sahara Fan Model SF315

Materials  
1.2mm 304 Grade St/ Steel Top & Supports  
0.7mm 430 Grade St/ Steel Internal Structure  
0.7mm Galvanised Steel Undercarrage  
6mm Tempered Glass  
Quartz Lamps

Installation  
Counter Top Flush Fit Cut Out Dimensions  
1492mm x 666mm x 25mm  
Counter Support Cut Out Dimensions  
1468mm x 642mm

ALL SHEET METAL DIMENSIONS ARE I/S (INSIDE SIZES) (UNLESS OTHERWISE STATED) ALL DIMENSIONS IN (mm), TOLERANCE = LINEAR ± 0.5mm, ANGULAR ± 0.5mm (OR AS STATED). ALL SHARP EDGES TO BE REMOVED FROM SHEET METAL PARTS

Product	DROP-IN RANGE			Product No		<small>© No reproduction or publication of this drawing may be made, and no article may be manufactured or assembled in accordance with this drawing without prior written consent. This prohibition is a term of any contract relating to this drawing. Rights reserved under the Copyright Act 1956 as amended by the Design Copyright Act 1968.</small>	 The Catering Equipment Company	
Description	D4BMSLF							
Material/Finish	Thickness		Desp/Date			Dwg No.	DIP-020886	Issue
Legacy P/N	Weight	67kg	Quote No.					
Client			SO Number	N/A		Drawn By	ABB	-
Client Project			Approved By			Date	16/01/2019	