

**Important Design Parameters**

On the operators side of the Servery Counter a removable service panel is required to allow access to service heating elements etc. The dimensions of the access aperture must be no less than 669mm x 145mm.

Additionally access is required to manually operate the drain valve. Drain connection is via 15mm lever ball valve.

**Warning**

The unit must be manually filled with water. Capacity 13 litre  
A depth of 40mm must be maintained during operation.  
[water level marker fitted to element cover]

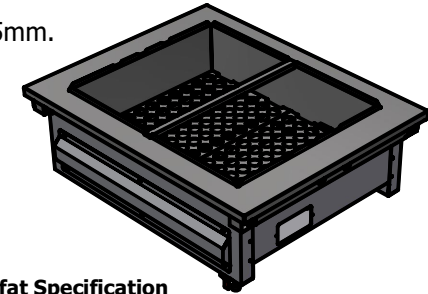

**Moffat Specification**

Wet Heat

Immersion heated Bainmarie Well

Dimensions

Width - 830mm  
Depth - 660mm  
Height - 266mm  
Weight - 27kg



Power Rating

2.0kw  
complete with a 2m long cord set & 13amp plug

Materials

1.2mm 304 Grade St/ Steel Top, Supports & Well  
0.7mm 430 Grade St/ Steel External Structure  
0.7mm Galvanised Steel Undercarrage  
6mm Tempered Glass  
Quartz Lamps

Installation

Counter Top Flush Fit Cut Out Dimensions  
836mm x 666mm x 25mm  
Counter Support Cut Out Dimensions  
812mm x 642mm

Control Box

Panel Mounted Cut Out Dimension  
185mm x 120mm  
2m Long Power Cable Connecting  
Control Box to Base unit

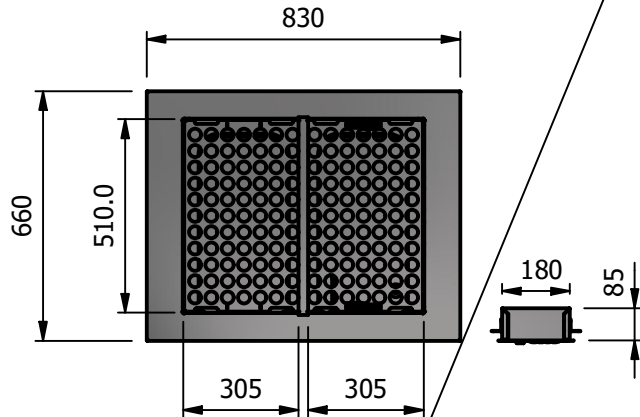

**A ( 1 : 10 )**

Panel Mounted Control Box

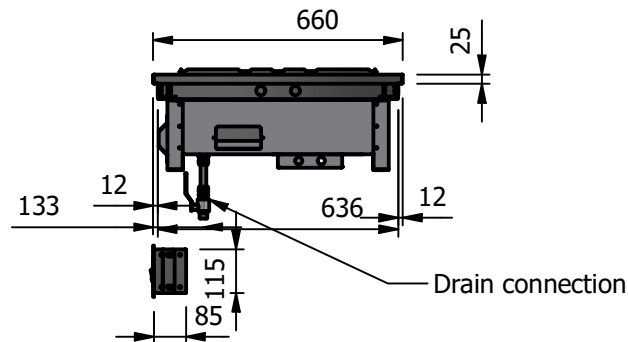
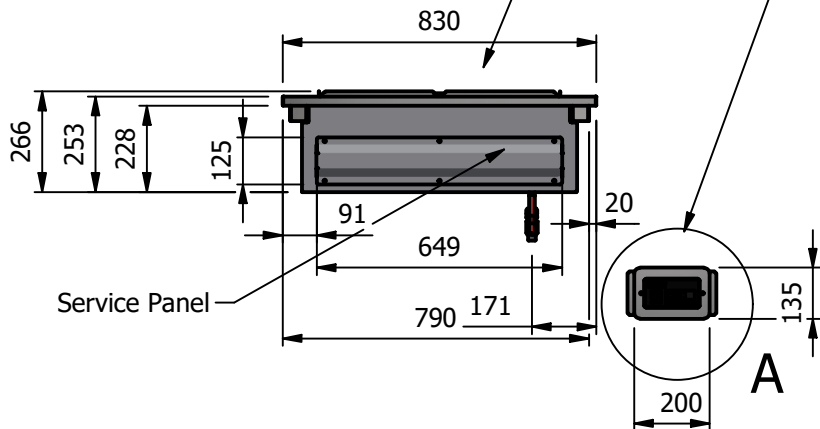
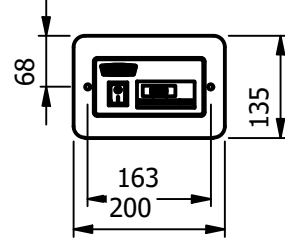

ALL SHEET METAL DIMENSIONS ARE I/S (INSIDE SIZES) (UNLESS OTHERWISE STATED)

ALL DIMENSIONS IN (mm), TOLERANCE = LINEAR ± 0.5mm, ANGULAR ± 0.5mm (OR AS STATED). ALL SHARP EDGES TO BE REMOVED FROM SHEET METAL PARTS

Product	DROP-IN RANGE			Product No	 The Catering Equipment Company			
Description	D2BMWNG							
Material/Finish	Thickness		Desp/Date		No reproduction or publication of this drawing may be made, and no article may be manufactured or assembled in accordance with this drawing without prior written consent. This prohibition is a term of any contract relating to this drawing. Rights reserved under the Copyright Act 1956 as amended by the Design Copyright Act 1968.			
Legacy P/N	Weight	27kg	Quote No.					
Client			SO Number	N/A	Dwg No.	DIP-022416	Issue	
Client Project			Approved By		Drawn By	ABB		
E & R MOFFAT LTD, SEABEGS ROAD, BONNYBRIDGE, FK4 2BS, T: +44 (0)1324 812272, E: sales@ermoffat.co.uk, Web: www.ermoffat.co.uk					Date	16/01/2019		
					Scale	1:20	Sheet	1 / 2
								<b>A4</b>