

Important Design Parameters

On the operators side of the Servery Counter a removable service panel is required to allow access to service heating elements etc. The dimensions of the access aperture must be no less than 669mm x 145mm.

Additionally access is required to manually operate the drain valve. Drain connection is via 15mm lever ball valve.

Warning

The unit must be manually filled with water. Capacity 13 litre
A depth of 40mm must be maintained during operation.
[water level marker fitted to element cover]

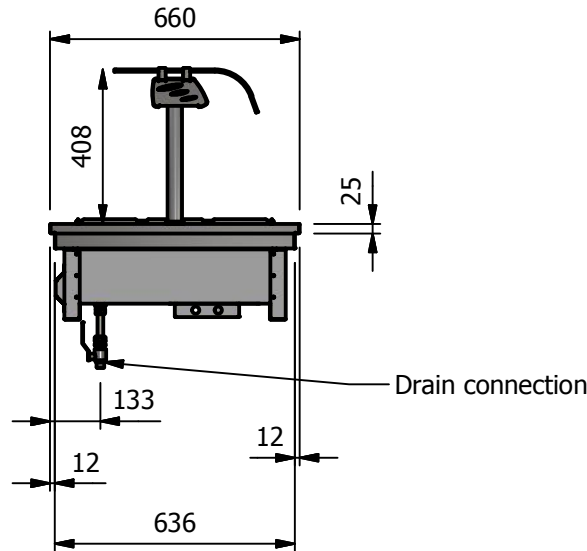
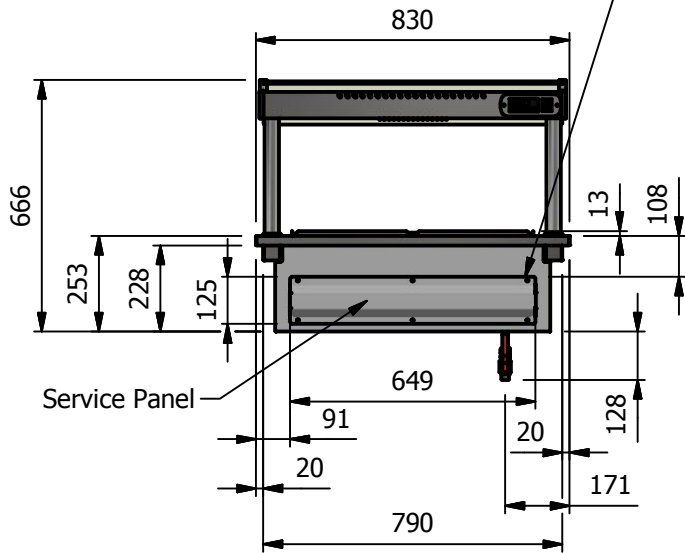
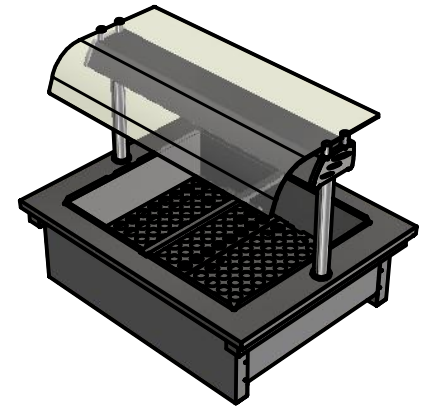

Moffat Specification

Wet Heat

Immersion heated Bainmarie Well

Dimensions

Width - 830mm

Depth - 660mm

Height - 666mm

Weight - 34kg

Power Rating

2.22kw

complete with a 2m long cord set & 13amp plug

Materials

1.2mm 304 Grade St/ Steel Top, Supports & Well

0.7mm 430 Grade St/ Steel External Structure

0.7mm Galvanised Steel Undercarrage

6mm Tempered Glass

Quartz Lamps

Installation

Counter Top Flush Fit Cut Out Dimensions

836mm x 666mm x 25mm

Counter Support Cut Out Dimensions

812mm x 642mm

ALL SHEET METAL DIMENSIONS ARE I/S (INSIDE SIZES) (UNLESS OTHERWISE STATED)

ALL DIMENSIONS IN (mm), TOLERANCE = LINEAR ± 0.5mm, ANGULAR ± 0.5mm (OR AS STATED). ALL SHARP EDGES TO BE REMOVED FROM SHEET METAL PARTS

Product	DROP-IN RANGE			Product No	 The Catering Equipment Company				
Description	D2BMW								
Material/Finish	Thickness		Desp/Date		<small>No reproduction or publication of this drawing may be made, and no article may be manufactured or assembled in accordance with this drawing without prior written consent. This prohibition is a term of any contract relating to this drawing. Rights reserved under the Copyright Act 1956 as amended by the Design Copyright Act 1968.</small>				
Legacy P/N	Weight	34kg	Quote No.						
Client			SO Number	N/A	Dwg No.	DIP-022394	Issue		
Client Project			Approved By		Drawn By	ABB	-		
E & R MOFFAT LTD, SEABEGS ROAD, BONNYBRIDGE, FK4 2BS, T: +44 (0)1324 812272, E: sales@ermoffat.co.uk, Web: www.ermoffat.co.uk					Date	16/01/2019			
					Scale	1:20	Sheet	1 / 2	A4