

Sahara Fan Model SF309

Glass Shelf 704mm 260mm

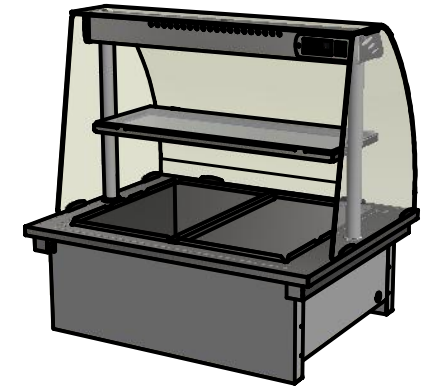
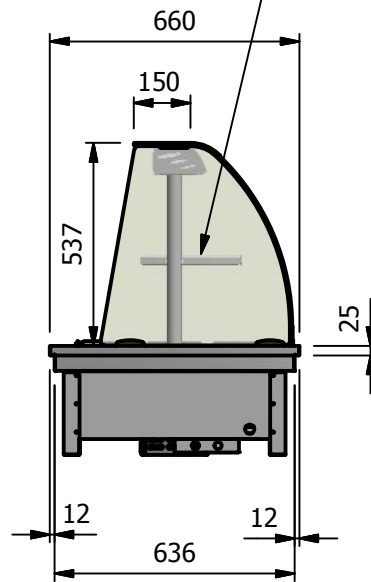

**Moffat Specification**

Dry Heat  
Fan Assisted Bainmarie Well

Dimensions  
Width - 830mm  
Depth - 660mm  
Height - 825mm  
Weight - 40kg

Power Rating  
1.12kw  
complete with a 2m long cord set & 13amp plug  
Removable Fan heating System Sahara Fan Model SF309

Materials  
1.2mm 304 Grade St/ Steel Top & Supports  
0.7mm 430 Grade St/ Steel Internal Structure  
0.7mm Galvanised Steel Undercarrage  
6mm Tempered Glass  
Quartz Lamps

Installation  
Counter Top Flush Fit Cut Out Dimensions  
836mm x 666mm x 25mm  
Counter Support Cut Out Dimensions  
812mm x 642mm

ALL SHEET METAL DIMENSIONS ARE I/S (INSIDE SIZES) (UNLESS OTHERWISE STATED)

ALL DIMENSIONS IN (mm), TOLERANCE = LINEAR ± 0.5mm, ANGULAR ± 0.5mm (OR AS STATED). ALL SHARP EDGES TO BE REMOVED FROM SHEET METAL PARTS

Product	DROP-IN RANGE			Product No	 The Catering Equipment Company	
Description	D2BMD					
Material/Finish	Thickness		Desp/Date		<small>No reproduction or publication of this drawing may be made, and no article may be manufactured or assembled in accordance with this drawing without prior written consent. This prohibition is a term of any contract relating to this drawing. Rights reserved under the Copyright Act 1956 as amended by the Design Copyright Act 1968.</small>	
Legacy P/N	Weight	40kg	Quote No.	Dwg No.		
Client			SO Number	N/A	DIP-020160	
Client Project			Approved By		Issue	
E & R MOFFAT LTD, SEABEGS ROAD, BONNYBRIDGE, FK4 2BS, T: +44 (0)1324 812272, E: sales@ermoffat.co.uk, Web: www.ermoffat.co.uk					Scale	1:20
					Sheet	1 / 2
						<b>A4</b>