

Full length bumper on both sides

Photo electric sensor automatically prevents trays clashing.

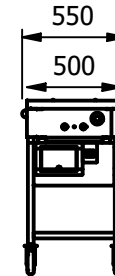
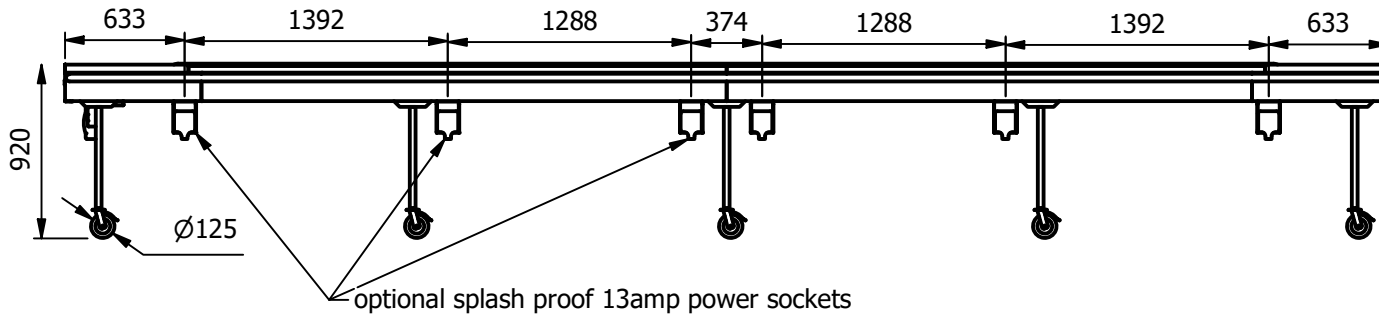

Moffat Specification

Round cord type conveyor.
 Sensor limit switch at the end of the conveyor
 Emergency-stop button at each end.
 Speed adjustable from 0 to 12 metres/minute
 Maintenance-free drum motor

Dimensions

Length - 7000mm
 Depth - 550mm
 Height - 920mm
 Weight - 90kg

Materials

1.2mm 304 Grade St/ Steel Chassis Top & Supports.
 0.7mm 430 Grade St Steel Ancillary Parts.

Mobility

Castors :- Swivel Type With Brakes.

ALL SHEET METAL DIMENSIONS ARE I/S (INSIDE SIZES) (UNLESS OTHERWISE STATED)

ALL DIMENSIONS IN (mm), TOLERANCE = LINEAR ± 0.5mm, ANGULAR ± 0.5mm (OR AS STATED). ALL SHARP EDGES TO BE REMOVED FROM SHEET METAL PARTS

Product	CONVEYOR			Product No		<p>The Catering Equipment Company</p>	<small>No reproduction or publication of this drawing may be made, and no article may be manufactured or assembled in accordance with this drawing without prior written consent. This prohibition is a term of any contract relating to this drawing. Rights reserved under the Copyright Act 1956 as amended by the Design Copyright Act 1968.</small>				
Description	CVC7M *** 7 METRE MOBILE CORD ***						Dwg No.	VCP-088272-1	Issue		
Material/Finish	Thickness			Desp/Date		Drawn By	N.Raymen	-			
Legacy P/N	Weight	90kg		Quote No.		Date	16/02/2021				
Client				SO Number	STANDARD	Approved By					
Client Project											
E & R MOFFAT LTD, SEABEGS ROAD, BONNYBRIDGE, FK4 2BS, T: +44 (0)1324 812272, E: sales@ermoffat.co.uk, Web: www.ermoffat.co.uk							Scale	1 : 40	Sheet	1 / 2	A4