

Full length bumper on both sides

Photo electric sensor automatically prevents trays clashing.

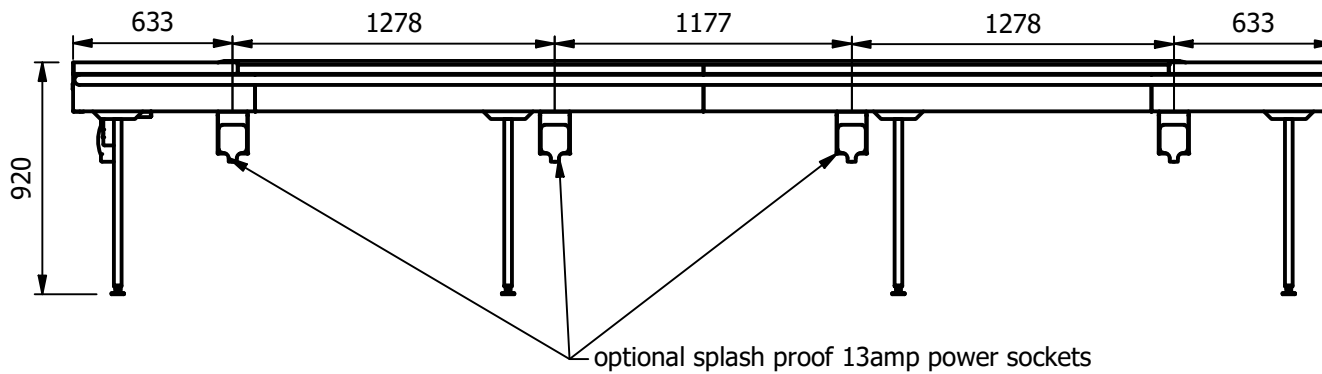

optional splash proof 13amp power sockets

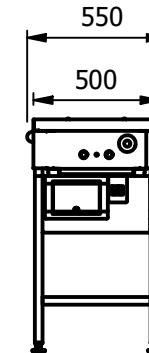

Moffat Specification

Round cord type conveyor.
 Sensor limit switch at the end of the conveyor
 Emergency-stop button at each end.
 Speed adjustable from 0 to 12 metres/minute
 Maintenance-free drum motor

Dimensions

Length - 5000mm
 Depth - 550mm
 Height - 920mm
 Weight - 80kg

Materials

1.2mm 304 Grade St/ Steel Chassis Top & Supports.
 0.7mm 430 Grade St Steel Ancillary Parts.

Mobility

Floor fixing adjustable for height feet

ALL SHEET METAL DIMENSIONS ARE I/S (INSIDE SIZES) (UNLESS OTHERWISE STATED)

ALL DIMENSIONS IN (mm), TOLERANCE = LINEAR ± 0.5mm, ANGULAR ± 0.5mm (OR AS STATED). ALL SHARP EDGES TO BE REMOVED FROM SHEET METAL PARTS

Product	CONVEYOR			Product No		<small>No reproduction or publication of this drawing may be made, and no article may be manufactured or assembled in accordance with this drawing without prior written consent. This prohibition is a term of any contract relating to this drawing. Rights reserved under the Copyright Act 1956 as amended by the Design Copyright Act 1968.</small>	 The Catering Equipment Company			
Description	CVC5S *** 5 METRE STATIC CORD ***									
Material/Finish	Thickness		Desp/Date			Dwg No.	VCP-088257-1	Issue		
Legacy P/N	Weight	80kg	Quote No.							
Client			SO Number	STANDARD		Drawn By	N.Raymen	-		
Client Project			Approved By			Date	16/02/2021			
E & R MOFFAT LTD, SEABEGS ROAD, BONNYBRIDGE, FK4 2BS, T: +44 (0)1324 812272, E: sales@ermoffat.co.uk, Web: www.ermoffat.co.uk						Scale	1 : 30	Sheet	1 / 2	A4